

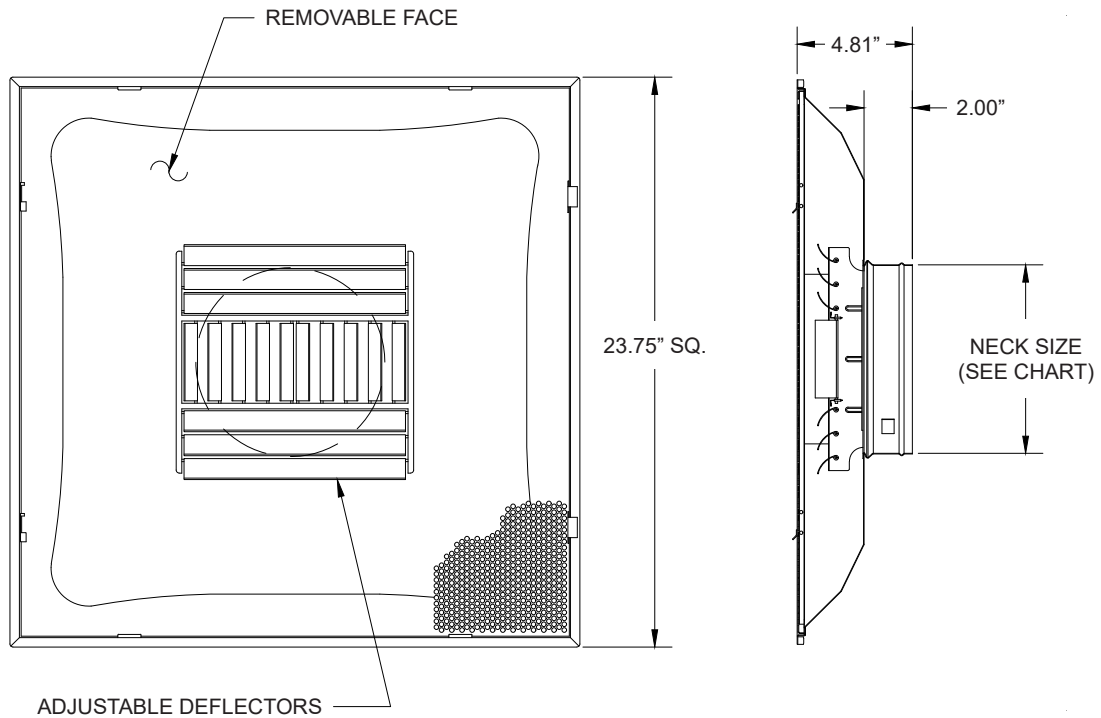

LCPS LIGHT COMMERCIAL CURVED BLADE PERFORATED SUPPLY W/ COLLAR



- Fits In Standard 24"x 24" T-bar Lay-In Ceiling Systems
- 4-Way Perforated Steel Face Construction
- Adjustable Curved Blade Deflectors
- Removable Hinged Face
- Formed Metal Back Panel With Fixed Collar
- Optional Butterfly Damper (MFLCBD Series)
- Face Finish: White

Curved Blade Perforated Supply - 1 Way

Neck Size (Dia.)		Neck Velocity (FPM)							
		300	400	500	600	700	800	1000	1200
6"	cfm	60	80	100	120	140	160	200	240
An .20	Ps	0.059	0.080	0.100	0.151	0.202	0.258	0.400	0.581
Ak .87	Throw	3/4/5	4/5/6	4/6/7	5/7/9	6/8/10	7/10/12	8/12/15	10/14/17
8"	cfm	105	140	175	210	245	280	350	420
An .35	Ps	0.080	0.110	0.160	0.240	0.320	0.420	0.650	0.930
Ak 1.11	Throw	4/6/7	6/8/10	7/10/12	8/12/15	9/14/17	11/15/19	14/20/24	16/24/29
10"	cfm	165	220	275	330	385	440	550	660
An .54	Ps	0.080	0.110	0.170	0.250	0.320	0.430	0.660	0.940
Ak 1.39	Throw	5/7/9	7/10/12	8/12/15	10/15/18	11/17/20	13/19/23	16/24/29	19/29/34



LCPS

LIGHT COMMERCIAL CURVED BLADE PERFORATED SUPPLY W/ COLLAR

(Continued)

Curved Blade Perforated Supply - 2 Way

Neck Size (Dia.)		Neck Velocity (FPM)							
		300	400	500	600	700	800	1000	1200
6"	cfm	60	80	100	120	140	160	200	240
An .20	Ps	0.050	0.070	0.090	0.130	0.171	0.220	0.338	0.500
Ak .87	Throw	2/3/4	3/4/5	4/5/6	4/6/7	5/7/8	5/8/9	7/10/12	8/12/14
8"	cfm	105	140	175	210	245	280	350	420
An .35	Ps	0.040	0.054	0.082	0.120	0.165	0.215	0.330	0.480
Ak 1.11	Throw	3/5/6	4/6/7	5/7/9	6/9/10	7/10/12	8/11/13	10/14/17	11/17/20
10"	cfm	165	220	275	330	385	440	550	660
An .54	Ps	0.060	0.080	0.130	0.180	0.250	0.310	0.510	0.730
Ak 1.39	Throw	5/7/8	6/9/10	7/11/13	9/13/15	10/15/18	11/17/20	14/21/25	17/25/30

Curved Blade Perforated Supply - 3 Way

Neck Size (Dia.)		Neck Velocity (FPM)							
		300	400	500	600	700	800	1000	1200
6"	cfm	60	80	100	120	140	160	200	240
An .20	Ps	0.020	0.030	0.040	0.059	0.080	0.102	0.150	0.230
Ak .87	Throw	3/4/5	3/5/6	4/6/7	5/7/8	5/8/9	6/9/11	8/11/14	9/13/16
8"	cfm	105	140	175	210	245	280	350	420
An .35	Ps	0.020	0.030	0.040	0.060	0.080	0.100	0.160	0.220
Ak 1.11	Throw	3/4/5	4/6/7	5/7/9	6/8/10	7/10/12	8/11/14	9/14/16	11/17/20
10"	cfm	165	220	275	330	385	440	550	660
An .54	Ps	0.030	0.040	0.060	0.090	0.120	0.150	0.240	0.340
Ak 1.39	Throw	5/7/8	6/9/11	7/11/13	9/13/15	10/15/18	12/17/21	14/21/25	17/25/30

Curved Blade Perforated Supply - 4 Way

Neck Size (Dia.)		Neck Velocity (FPM)							
		300	400	500	600	700	800	1000	1200
6"	cfm	60	80	100	120	140	160	200	240
An .20	Ps	0.010	0.010	0.020	0.030	0.040	0.050	0.080	0.120
Ak .87	Throw	2/2/3	2/3/3	2/3/4	3/4/5	3/5/6	4/5/6	4/6/7	5/8/9
8"	cfm	105	140	175	210	245	280	350	420
An .35	Ps	0.010	0.010	0.020	0.030	0.040	0.060	0.090	0.120
Ak 1.11	Throw	2/3/3	2/3/4	3/4/5	4/5/6	4/6/7	5/7/8	6/8/10	7/10/12
10"	cfm	165	220	275	330	385	440	550	660
An .54	Ps	0.010	0.020	0.030	0.040	0.060	0.070	0.110	0.160
Ak 1.39	Throw	3/4/5	4/6/7	5/7/8	6/8/10	6/9/11	7/11/13	9/13/16	11/16/19