

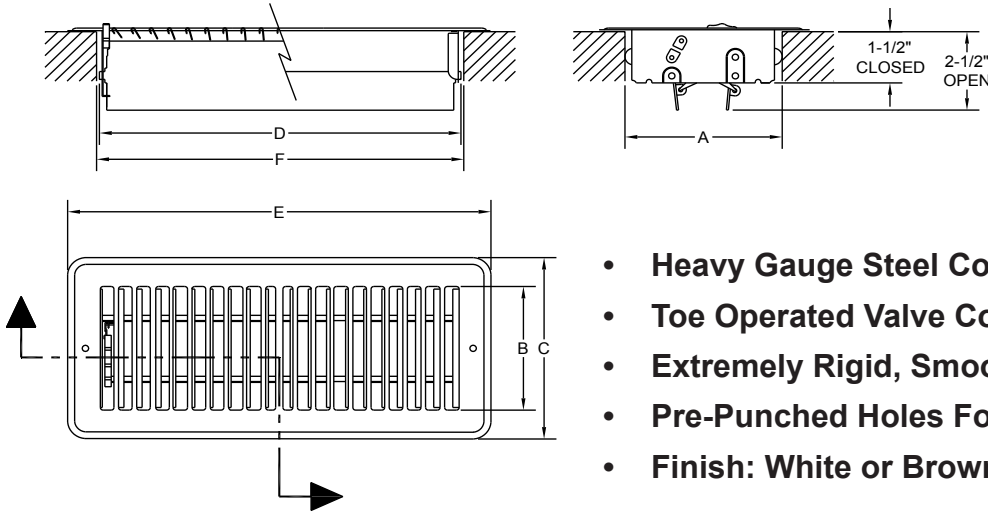

# MOBILE HOME FLOOR REGISTER SPECIFICATION CHART



- Heavy Gauge Steel Construction
- Toe Operated Valve Control
- Extremely Rigid, Smooth Surface Face
- Pre-Punched Holes For Screw Attachment
- Finish: White or Brown

Floor Register Dimensional Chart

Size (AxF)	Dimensions (See Detail Sketches)				Size (AxF)	Dimensions (See Detail Sketches)			
	Daylight Opening		Overall			Daylight Opening		Overall	
	B	C	D	E		B	C	D	E
2x10	2	3-3/4	9-5/8	11-1/2	4x10	3-3/4	5-1/2	9-5/8	11-1/2
2x12	2	3-3/4	11-5/8	13-1/2	4x12	3-3/4	5-1/2	11-5/8	13-1/2
2x14	2	3-3/4	13-5/8	15-1/2					

Floor Register

Face Velocity		295	395	490	590	690	785	885	985
Pressure Loss (In H <sub>2</sub> O)		0.006	0.010	0.015	0.022	0.030	0.039	0.050	0.061
2x10 A <sub>k</sub> =0.083	cfm	25	33	41	49	57	65	74	82
	throw (ft.)	3.3	4.0	4.5	6.0	7.0	8.0	9.0	10.0
2x12 A <sub>k</sub> =0.100	cfm	30	40	50	60	70	80	90	100
	throw (ft.)	3.5	4.5	5.5	7.0	8.0	9.0	10.0	11.0
2x14 A <sub>k</sub> =0.117	cfm	35	46	58	69	81	92	104	115
	throw (ft.)	3.5	4.5	6.0	8.0	8.0	9.5	10.5	12.0
4x10 A <sub>k</sub> =0.156	cfm	46	61	77	92	107	123	138	153
	throw (ft.)	4.0	6.0	8.0	10.0	11.0	12.5	14.0	15.5
4x12 A <sub>k</sub> =0.195	cfm	55	74	92	111	129	148	166	185
	throw (ft.)	4.0	5.5	7.0	8.0	9.5	11.0	12.0	13.0

Terminal velocity of 50 fpm.