



INSTALLATION AND MAINTENANCE INSTRUCTIONS

RIGID MASONRY CHIMNEY LINERS



Listing No. MH 17528
Tested to UL1777
(for Chimney Liners)

Models:

PSW: 6"- 36"

FCGSW: 26"- 36"

FCSSW: 6"- 24"

CAUTION:

The Metal-Fab rigid masonry chimney lining systems have been designed to properly vent Category I (Model PSW) gas/propane burning appliances and Categories II, III and IV (Model FCGSW/FCSSW) gas burning appliances where the maximum appliance outlet temperatures must not exceed 550°F (288°C). Appliances burning solid or liquid fuels are not to be connected to this lining system.

Installation should be performed by an experienced professional familiar with the installation of chimney lining systems. The Metal-Fab rigid masonry chimney lining systems are to be installed and comply with the requirements of NFPA 211, Standard for chimneys, fireplaces, vents and solid fuel burning appliances. The installation and sizing must conform to the requirements of the appliance manufacturer's instructions. Contact local building or fire officials about restrictions and installations in your area.

The Metal-Fab rigid masonry lining systems have been properly designed to vent gas burning appliances. Substituting other parts not identified within these instructions may pose an unsafe installation. Acceptance of the lining system is void if the installation instructions are not followed.

INSTALLATION INSPECTION:

Prior to installing a liner system in a masonry chimney, the chimney is to be thoroughly cleaned and inspected. The chimney must be composed of solid masonry units, such as bricks or concrete block, at least 4 inches (nominal) in thickness. Check for cracked loose or missing bricks, mortar or other materials that could inhibit correct liner installation. Repair chimney as required. Removal of all tar glazed creosote is a must prior to installation of chimney liner. Verify the air space clearances between the masonry chimney exterior and combustible materials are in accordance with applicable building code requirements.

Where a chimney terminates less than 10 feet from any adjacent ridge, wall or parapet, the chimney shall terminate at a minimum of 3 feet above the ridge, wall or parapet.

Where a chimney terminates more than 10 feet from any adjacent ridge, wall or parapet, a minimum height of 2 feet shall be required above the ridge wall or parapet. See **FIG.1**.

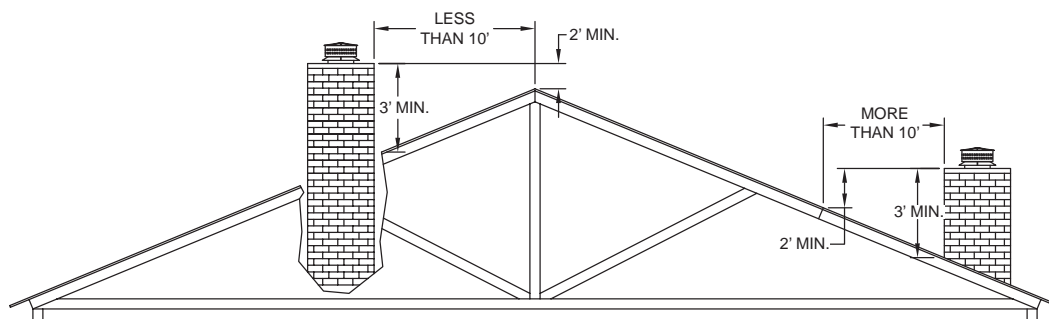

FIG. 1

General:

The PSW and FCGSW/FCSSW rigid lining systems are listed by UL for installation at zero clearance to the inside masonry surface and with zero clearance from the outside surface of the masonry chimney and surrounding combustible material.

Do not place insulation or other materials in required clearance spaces surrounding the liner unless otherwise specified. If necessary, construct a barrier to prevent loose insulation from falling against chimney. Make sure that the flue space is large enough, at its smallest point, to accommodate the vent flue diameter.

Refer to the following installation and maintenance instructions for installation and product assembly details beyond the masonry chimney.

FCGSW - Metal-Fab Instructions L2796
FCSSW - Metal-Fab Instructions L2591
PSW - Metal-Fab Instructions L2502

Joint Assembly – PSW/FCGSW/FCSSW:

The Models PSW/FCGSW/FCSSW joint sealing system is designed for quick and easy installation. See **FIG 2** and **FIG 2A**.

1. Inspect flanged surfaces just prior to installation, and if contaminated with oil or dirt, clean with rubbing alcohol. Apply a continuous bead of P070 sealant to one of the flanges to be joined. **FIG 2**.

Note: For FCSSW (Sleeved), apply a continuous bead of P070 sealant in the corner of the sleeve and flange. When assembling FCSSW, always align "UP" arrow (per UL label) away from the appliance. **FIG 2A**.

2. Join the two flanged ends of the pipe sections compressing the P070 sealant just applied.
3. Fill the channel of flange band with P070 sealant.
4. Install the flange band around the flanges and firmly tighten (Torque: 2 ft-lbs to 5 ft-lbs).

DO NOT over tighten for risk of damage to joint.

Note: Allow P070 sealant to cure 24 hours before operating appliances.

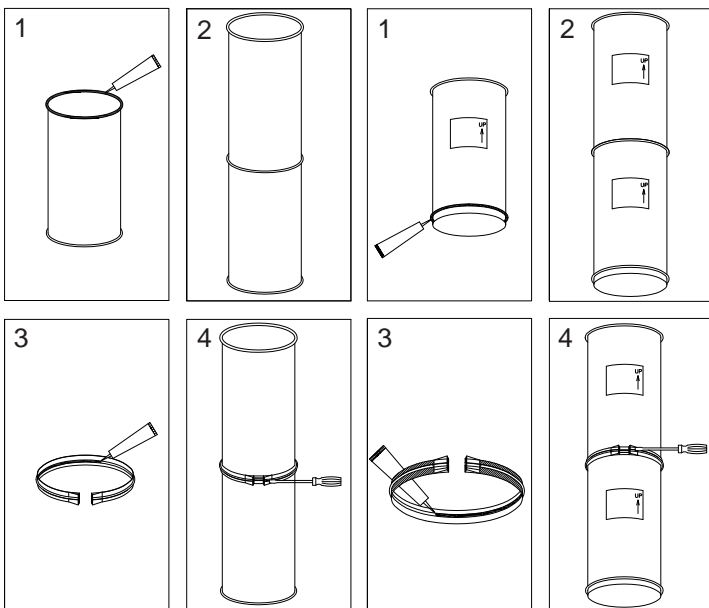

FIG 2

FIG 2A

Support Method and Height Limits:

Vertical supports and height limits are shown in **TABLE 1**.

Support Method	Pipe Dia./Model	Max Height
Plate Support	6"-12"(152-305)FCSSW	100'(30.5)
	14"-24"(356-610)FCSSW	75'(22.9)
	26"-36"(660-914)FCGSW	100'(30.5)
	6"-36"(152-914)PSW	100'(30.5)
Lifting Support Ring	6"-36"(152-914)FCGSW/FCSSW	60'(18.3)
	6"-36"(152-914)PSW	60'(18.3)
Stack Support (On Foundation)	6"-36"(152-914)FCGSW/FCSSW	100'(30.5)
	6"-36"(152-914)PSW	100'(30.5)

TABLE 1

Vertical vent liner systems can be suspended pre-assembled and lowered into a shaft. Refer to **TABLE 2** for maximum height that can be suspended from overhead. Do not pre-assemble in the horizontal position and rise to the vertical position for installation.

Warning: All joints must be properly assembled and allowed to cure before lifting for installation.

FCGSW/PSW/FCSSW			
Diameter	Height	Diameter	Height
6" (152)	229' (70)	20" (508)	105' (32)
* 7" (178)	215' (66)	22" (559)	95' (29)
8" (203)	200' (61)	24" (610)	90' (27)
* 9" (229)	190' (58)	26" (660)	90' (27)
10" (254)	175' (53)	28" (711)	90' (27)
12" (305)	145' (44)	30" (762)	80' (24)
14" (356)	120' (37)	32" (813)	80' (24)
16" (406)	120' (37)	34" (864)	70' (21)
18" (457)	105' (32)	36" (914)	70' (21)

*Diameters not available for Models PSW

TABLE 2

Installation:

A. Open the chimney for Tee or Elbow:

Note: Wear protective eye wear, gloves and respirator. An opening must be made in the masonry chimney in which the appliance is located. If the chimney already has an opening, it will probably require expansion to facilitate installation of the base assembly. Locate the hole for the appliance breaching considering available headroom and clearance to combustibles. Consult the appliance manufacturer's instructions and the applicable local codes to determine clearance needed for the vent or chimney connector. An additional opening may be needed for a cleanout tee or drain section. The size of the hole will depend on the type of support system to be used with the installation. Use the instructions packaged with the support for assembly details.

When a tee or elbow is to be used for the appliance connection it may be pre-connected to the sections of vertical flue gas liner and lowered down the chimney. The chimney flue space must be large enough to accommodate the horizontal take-off from the elbow or the tee tap. If the flue space is not large enough, the elbow or tee will have to be attached to the bottom of the vertical liner after it is lowered down the chimney. See **FIG. 3**.

B. Pre-assemble lengths of liner:

Note: Never drill through the liner wall or attempt to join sections or components using screws or pop rivets. Sections of the Metal-Fab rigid liner may be pre-assembled and lowered down the shaft. The maximum suspended height is shown in TABLE 2. Do not exceed the maximum height limits of the lifting support ring or plate supports when lowering down the shaft. All joints must be assembled properly and allowed to cure before installation. Be sure to check for overhead power lines and other obstacles, and provide safe stable footing before working with long lengths of liner sections. See **FIG. 4**.

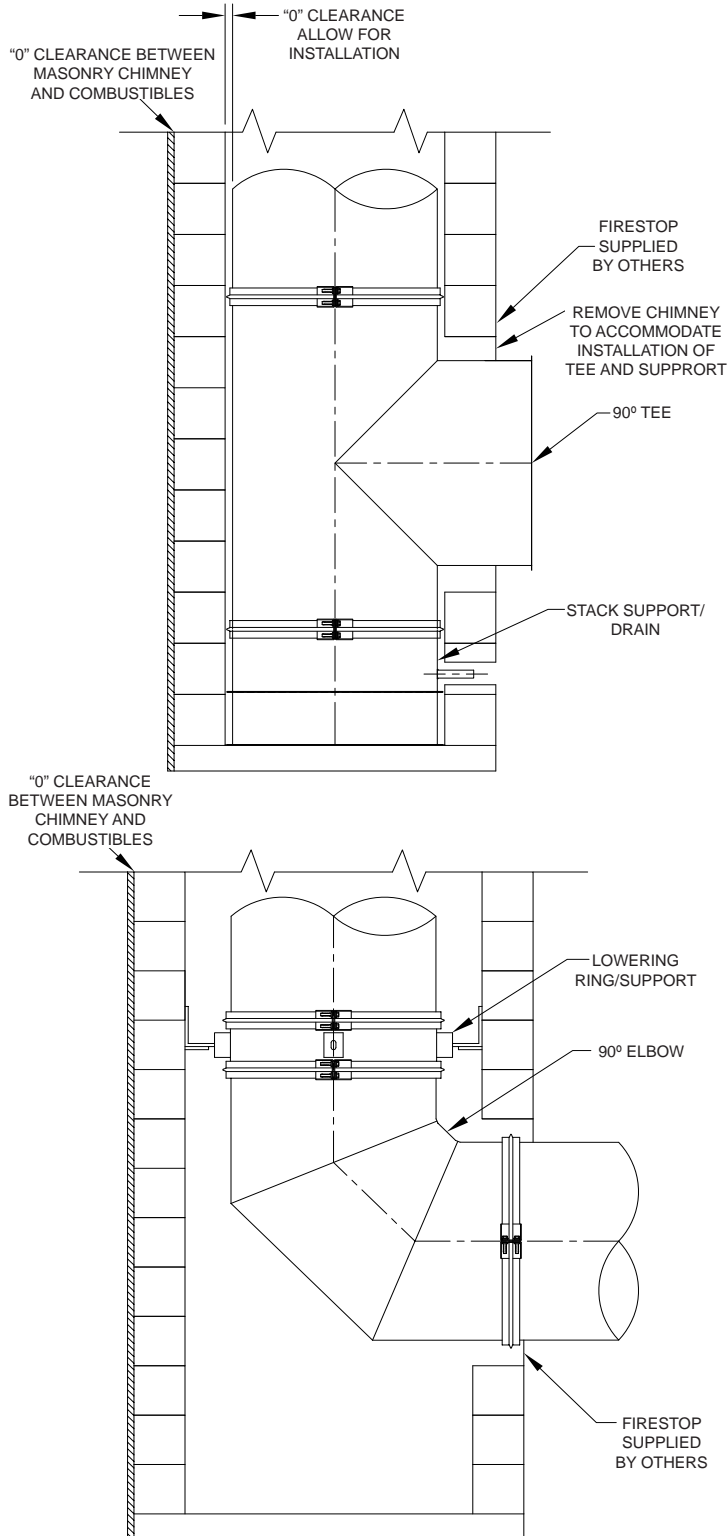

FIG. 3

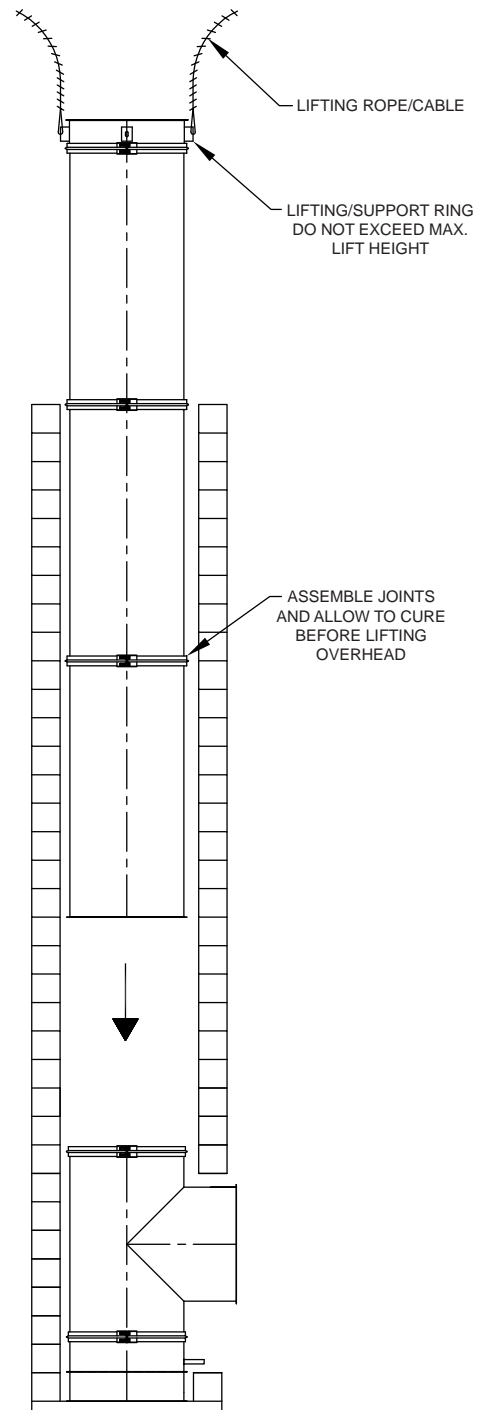

FIG. 4

C. Lowering Liner as Assembled:

The lifting support ring attached by rope/cable will allow the liner to be safely and smoothly lowered down the masonry chimney and be held in position while additional lengths are attached. Attach the rope/cable to the lifting lugs around the lifting support ring. Attach the first length of liner to the lifting support ring per the assembly method noted above and lower the liner into the masonry chimney. See **FIG. 5**. Continue attaching sections of liner and lower to the bottom opening until proper height is complete. Attach the tee or elbow at the bottom opening of masonry chimney if clearances will not allow it to be lowered from the top. Attach supports at maximum heights shown in Table 1. It is recommended to guide the liner every 25' (within the masonry chimney) if clearances allow. Close opening of masonry chimney with a fire stop (supplied by others). See **FIG. 6**.

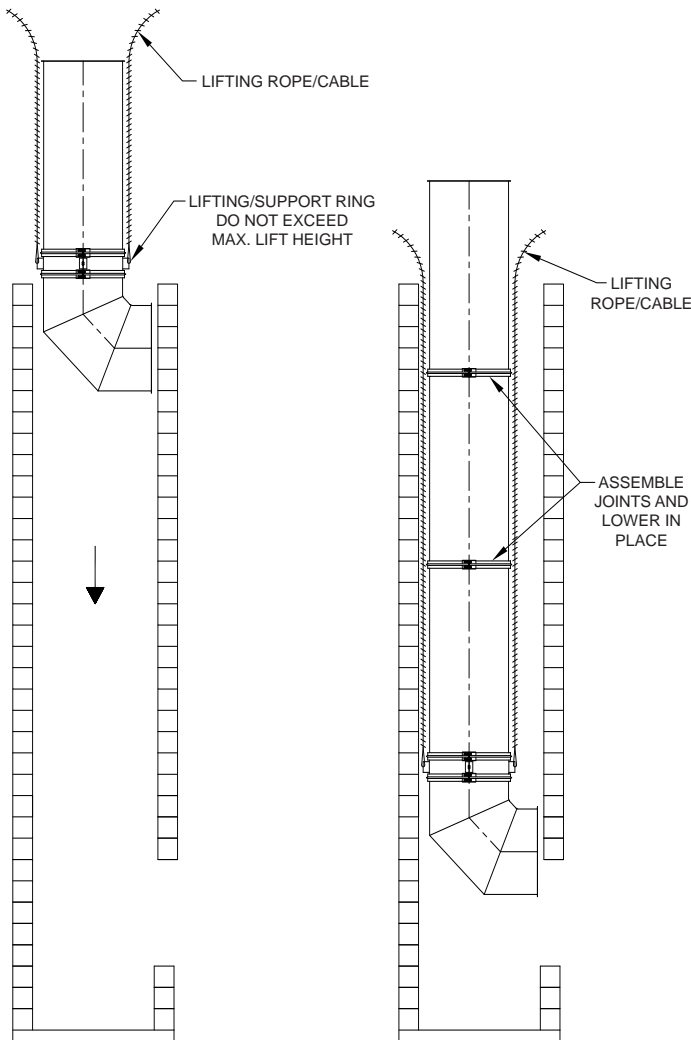

FIG. 5

D. Install Termination:

Trim the masonry cover plate so that the hole is centered over the rigid liner. Slide cover plate over rigid liner and secure to masonry chimney. Install flashing over rigid liner and secure the base to the cover plate using mechanical fasteners and sealing around flashing plate with silicone caulk. Attach the storm collar around the liner above the flashing and secure in place with the locking tab and strap. Seal between the storm collar and liner with silicone caulk. Attach the termination cap to the top liner section. The maximum height for the termination cap above the chimney is 5'. For heights that exceed 5' guying is required.

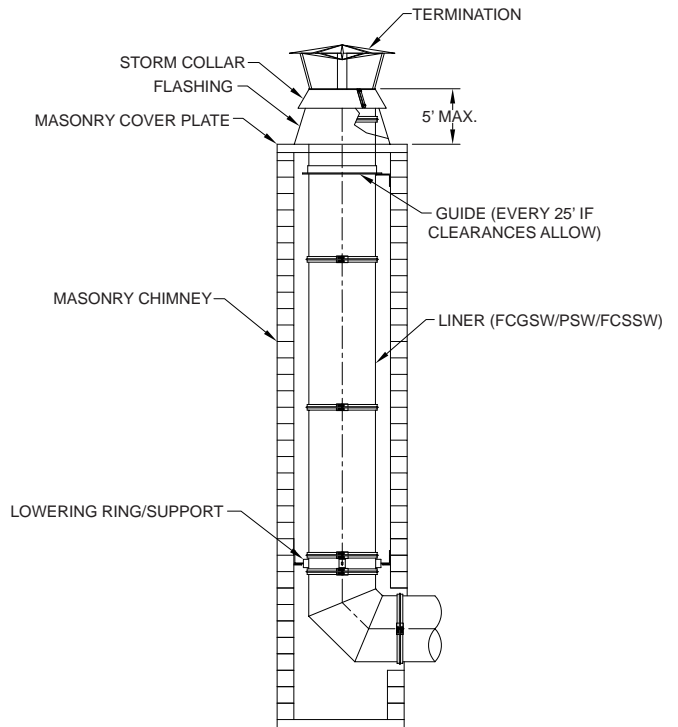

FIG. 6

Maintenance Instructions:

As with all vents the rigid liner vent system should be inspected at least annually for the presence of deposits or debris and any accumulation should be removed. The liner system should also be inspected at regular periods for signs of leakage of condensate or combustion products at any joints.

If the liner system incorporates a drain hose from either an inline fitting or from a drain tee, the hose must be inspected periodically to ensure that water is in the trap loop. If a proper trap loop is not maintained, exhaust from the connected appliances may accumulate in the building area.



P.O. Box 1138 • WICHITA, KS 67201
(316)943-2351 • Fax (316)943-2717

© 2015 Metal-Fab, Inc. Form No. L2750 6/15
9422