



CORR/GUARD INSTALLATION INSTRUCTIONS

This symbol on the nameplate
means this product is listed by
Underwriters Laboratories Inc.
Tested to UL1738 / CAN / ULCS636-08
Listing No. MH26687
Testing No. 11EN



SMALL DIAMETER CORR/GUARD & SLEEVED CORR/GUARD

PRESSURE RATED VENTING SYSTEM
UNS S44735 (I.E. AL29-4C) STAINLESS STEEL

CONDENSING APPLIANCES
CAT. II, III, IV APPLIANCES
FUME EXHAUST

3"(76mm) - 36"(914mm) DIAMETERS

**IMPORTANT: DO NOT INSTALL WITHOUT FIRST READING THESE INSTRUCTIONS
VERY CAREFULLY.**

- EXAMINE ALL COMPONENTS FOR POSSIBLE SHIPPING DAMAGE BEFORE INSTALLATION.
- PROPER JOINT ASSEMBLY IS ESSENTIAL FOR A SAFE INSTALLATION. FOLLOW THESE INSTRUCTIONS EXACTLY AS WRITTEN. CHECK SEVERENESS OF JOINTS UPON COMPLETION OF ASSEMBLY.
- THIS VENTING SYSTEM MUST BE FREE TO EXPAND AND CONTRACT. SUPPORT SYSTEM IN ACCORDANCE WITH THESE INSTRUCTIONS. CHECK FOR UNRESTRICTED MOVEMENT THROUGH WALLS, CEILINGS, AND ROOF PENETRATIONS. DIFFERENT MANUFACTURERS HAVE DIFFERENT JOINT SYSTEMS AND ADHESIVES. DO NOT MIX PIPE, FITTINGS, OR JOINING METHODS FROM DIFFERENT MANUFACTURERS.

METAL-FAB, INC. P.O. BOX 1138, WICHITA, KS 67201-1138

GENERAL

CORR/GUARD VENTING SYSTEM INSTALLATION INSTRUCTIONS

Corr/Guard is a special stainless steel venting system for gas-fired appliances listed as Cat. II, III & IV or in Canada, Type BH Gas Venting Systems per ULC-636, with rated operating temperature of 550° F (287° C). Corr/Guard is rated for positive pressure of 15" (381mm) w.c. for 3" (76mm) diameter through 36" (914mm) diameter. Metal-Fab, Inc. recommends the system be inspected once a year by a qualified service technician.

Venting system design may be limited by appliance performance. Consult appliance installation instructions to determine proper sizing and limitations such as maximum horizontal length and height, maximum number of elbows or offsets, connecting two or more appliances to a common venting system, and other limitations that may affect design and installation. Permits may be required before starting an installation. Installation is to be in accordance with local building code requirements and National Codes: USA – NFPA 54 ANSI-Z223.1 or NFPA 211. In Canada – CAN/CGA-B149.1 or CAN/CGA-B149.2 Propane Installation Code as applicable. **It is the responsibility of the installer to contact local building and fire officials concerning any installation restrictions and/or inspection requirements that may apply.**

Corr/Guard is to be installed in accordance with these installation instructions and those of the appliance manufacturer. For conditions and applicable restrictions not specifically mentioned herein, contact building or fire officials having jurisdiction in your area. The following is a guide to assist a professional installer:

- Proper operation of the venting system and appliance is dependant on the use of all parts specified by Metal-Fab for use in the particular installation. System performance may be affected if the proper assembly of all required parts is not accomplished.
- Refer to appliance's instructions to determine proper sizing and connection of the venting system to the appliance.
- Corr/Guard Model CG, FCS, FCS-1 & FCS-2 double wall vent may be used with Model CGSW & FCSSW single wall vent within the same vent system.
- Tee sections should only be used in conjunction with a drain on appliances tested for use with a drain, or if allowed by the appliance manufacturer for multiple appliance connections.
- If required by the appliance manufacturer, a drain fitting must be located as close as possible to the appliance flue outlet. Unless a drain fitting is supplied with the appliance, install only a Corr/Guard Drain Fitting.
- More than one Category II, III or IV appliance may not be connected into the same vent system, unless the appliance manufacturer specifically approved such a system and the appliances are designed for multiple venting. Cat. II, III or IV appliances MAY NOT share any part of their vent system with a natural draft appliance.
- Check the joints and seams for gas tightness when using the venting system with a Cat. III or Cat. IV appliance.
- Except for installation in one and two family dwellings, a venting system that extends through any zone above that on which the connected appliance is located shall be provided with an enclosure having a fire resistance rating equal to or greater than that of the floor or roof assemblies through which it passes.
- Corr/Guard shall not be routed into, through, or within any other vent, such as an existing masonry or factory-built chimney flue that is connected to another appliance.
- **WARNING! Do not place or install insulation in any required clearance spaces surrounding the venting system.**
- Enclosure of exterior mounted venting systems below the roof line is recommended to limit condensation and protect from mechanical damage.

When the Corr/Guard vent system is installed, check joints for tightness. Repair any joint leaks by disassembling and resealing following the guidelines in the Joint Assembly section of these instructions. Replace any defective component.

The Corr/Guard ventilation system, manufactured by Metal-Fab, Inc. is constructed to exacting standards. The proper operation of this vent system is dependant on the use of correct components, proper sizing, quality of installation, and guidelines and limitations expressed by the appliance manufacturer.

(TABLE 1) CLEARANCE TO COMBUSTIBLES					
Corr/Guard SINGLE WALL (CGSW & FCSSW)					
Rated Operating		Minimum Clearance		Minimum Clearance	
Temperatures		Enclosed		Unenclosed	
Pipe Dia.	Temp.	Horiz.	Vert.	Horiz.	Vert.
Single Wall 3" & 4" (76mm - 102mm) (CGSW)	400°F (204°C)	8" (203mm)	4" (102mm)	1" (25mm)	1" (25mm)
	480°F (249°C)	8" (203mm)	4" (102mm)	2" (51mm)	2" (51mm)
	550°F (288°C)	N/A	N/A	2" (51mm)	2" (51mm)
Single Wall 5" (127mm) (CGSW)	400°F (204°C)	N/A	6" (152mm)	1" (25mm)	1" (25mm)
	480°F (249°C)	N/A	6" (152mm)	2" (51mm)	2" (51mm)
	550°F (288°C)	N/A	N/A	2" (51mm)	2" (51mm)
Single Wall 6"-12" (152mm - 305mm) (FCSSW)	480°F (249°C)	N/A	N/A	2" (51mm)	2" (51mm)
	550°F (288°C)	N/A	N/A	2" (51mm)	2" (51mm)
Single Wall 14"-18" (356mm - 457mm) (FCSSW)	480°F (249°C)	N/A	N/A	3" (76mm)	3" (76mm)
	550°F (288°C)	N/A	N/A	3" (76mm)	3" (76mm)
Single Wall 20"-24" (508mm - 610mm) (FCSSW)	480°F (249°C)	N/A	N/A	4" (102mm)	4" (102mm)
	550°F (288°C)	N/A	N/A	4" (102mm)	4" (102mm)
Single Wall 26"-30" (660mm - 762mm) (FCSSW)	480°F (249°C)	N/A	N/A	5" (127mm)	5" (127mm)
	550°F (288°C)	N/A	N/A	5" (127mm)	5" (127mm)
Single Wall 32"-36" (813mm - 914mm) (FCSSW)	480°F (249°C)	N/A	N/A	6" (152mm)	6" (152mm)
	550°F (288°C)	N/A	N/A	6" (152mm)	6" (152mm)

(TABLE 1) CLEARANCE TO COMBUSTIBLES					
Corr/Guard DOUBLE WALL (CG, FCS, FCS-1 & FCS-2)					
Rated Operating		Minimum Clearance		Minimum Clearance	
Temperatures		Enclosed		Unenclosed	
Pipe Dia.	Temp.	Horiz.	Vert.	Horiz.	Vert.
Double Wall 3"-5" (76mm - 127mm) (CG)	300°F (149°C)	3" (76mm)	1" (25mm)	1" (25mm)	1" (25mm)
	480°F (249°C)	6" (152mm)	1" (25mm)	1" (25mm)	1" (25mm)
	550°F (288°C)	N/A	N/A	1" (25mm)	1" (25mm)
Double Wall 6"-12" (152mm - 305mm) (FCS/FCS-1/FCS-2)	480°F (249°C)	N/A	1" (25mm)	1" (25mm)	1" (25mm)
	550°F (288°C)	N/A	1" (25mm)	1" (25mm)	1" (25mm)
Double Wall 14"-18" (356mm - 457mm) (FCS/FCS-1/FCS-2)	480°F (249°C)	N/A	1" (25mm)	2" (51mm)	1" (25mm)
	550°F (288°C)	N/A	1" (25mm)	2" (51mm)	1" (25mm)
Double Wall 20"-24" (508mm - 610mm) (FCS/FCS-1/FCS-2)	480°F (249°C)	N/A	1" (25mm)	3" (76mm)	1" (25mm)
	550°F (288°C)	N/A	1" (25mm)	3" (76mm)	1" (25mm)
Double Wall 26"-30" (660mm - 762mm) (FCS/FCS-1/FCS-2)	480°F (249°C)	N/A	2" (51mm)	4" (102mm)	2" (51mm)
	550°F (288°C)	N/A	2" (51mm)	4" (102mm)	2" (51mm)
Double Wall 32"-36" (813mm - 914mm) (FCS/FCS-1/FCS-2)	480°F (249°C)	N/A	2" (51mm)	5" (127mm)	2" (51mm)
	550°F (288°C)	N/A	2" (51mm)	5" (127mm)	2" (51mm)

USE AND INSTALLATION OF INDIVIDUAL PARTS:

These instructions comprise both general and specific requirements for all parts in the product line. Before specifying a design or beginning an installation, these instructions should be carefully reviewed.

PIPE WEIGHT

The average weight of the chimney, per foot of length, can be calculated using the following formula.

FCSSW (6"-24"):	0.30 x diameter = lbs per foot
FCS (6"-24"):	0.70 x diameter = lbs per foot
FCS-1 (6"-24"):	0.85 x diameter = lbs per foot
FCS-2 (6"-24"):	0.95 x diameter = lbs per foot
FCSSW (26"-36"):	0.40 x diameter = lbs per foot
FCS (26"-36"):	0.80 x diameter = lbs per foot
FCS-1 (26"-36"):	0.95 x diameter = lbs per foot
FCS-2 (26"-36"):	1.05 x diameter = lbs per foot

Example: 8FCS-1: 0.85 x 8 = 6.80 lbs per foot

Vent design should make provisions for support adequate to ensure that vent components are not overloaded.

PART NUMBERS

These instructions identify Model FCS, FCS-1 & FCS-2 parts by name of part number in the text and illustrations. Actual parts also carry a flue diameter prefix and a three digit "CTO" suffix which defines the materials of construction, such as 8FCS24-CA1 for an 8-inch diameter double wall pipe section 24 inches long with UNS S44735 (i.e. AL29-4C) stainless steel inner flue wall, aluminized steel outer casing wall and 1" insulation. (See **TABLE 2** for further explanations of CTO codes).

TABLE 2

1ST DIGIT (INNER WALL)	2ND DIGIT (OUTER WALL)	3RD DIGIT (INSULATION)
C = UNS S44735	A = ALUMINIZED STEEL	0 = AIR SPACE
	4 = 304 S/S	1 = 1" INSULATION
	6 = 316 S/S	2 = 2" INSULATION

JOINT ASSEMBLY-SINGLE WALL

3"- 5" (76mm - 127mm) DIAMETER CGSW

Each Corr/Guard vent component contains a seal gasket on the female end of the vent joint and locking tabs. Mechanical fastening of the joint is automatic and requires no tools. Visually check the gasket for proper location within the pipe bead during assembly or flue gases could leak, resulting in carbon monoxide poisoning. Assembly of joints is shown below:

NOTE: When assembling 3"-5" Diameter Corr/Guard vent, always install the the female flue end elevated above the male flue end. The "UP" arrow will point to the elevated female flue end. Change of directions are made by using a male to male or female to female adapter depending on the flow of the condensate.

1. Insert the male end of the vent pipe into the adjoining female vent section until the bead of the male joint stops at the edge of the female joint.

NOTE: If the seal gasket pushes out of the groove during the assembly process, apply a light film of synthetic based lubricant to the top surface of the gasket or spray a light film of soapy water on the top surface of the gasket. Visually check that the gasket has not pushed out of the flue bead.

2. When properly inserted to the fullest extent, the integral locking tabs will snap into place, securing the joint **Before proceeding, verify that all locking tabs are engaged for each joint assembly.**

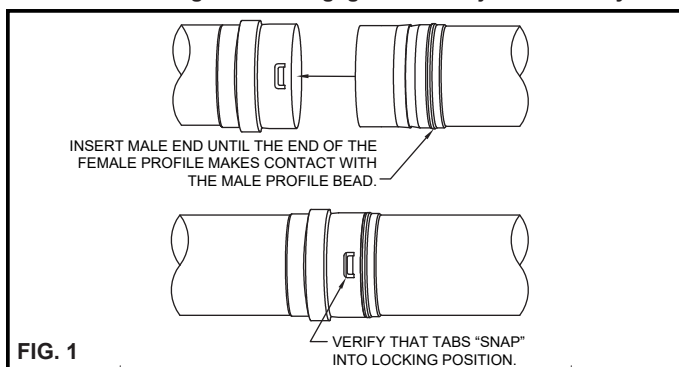

JOINT ASSEMBLY-DOUBLE WALL

3"- 5" (76mm - 127mm) DIAMETER CG

Connections between vent and fittings are male/female type. The inner duct is sealed with an integral seal gasket and the joint is mechanically secured via the overlapping outer wall of the double wall pipe.

NOTE: When assembling 3"-5" Diameter Corr/Guard vent, always install the the female flue end elevated above the male flue end. The "UP" arrow will point to the elevated female flue end. Change of directions are made by using a male to male or female to female adapter depending on the flow of the condensate.

Joints are assembled per the following steps:

1. Before assembly, observe that the seal gasket is located within the female inner pipe joint. Locate next pipe or fitting with male inner pipe joint and insert to begin engagement of inner pipe joint.
NOTE: If the seal gasket pushes out of the groove during the assembly process, apply a light film of synthetic based lubricant to the top surface of the gasket or spray a light film of soapy water on the top surface of the gasket. Visually check that the gasket has not pushed out of the flue bead.
2. As the joint further engages, align the male and female ends of the outer wall of each pipe so that they begin to engage as the pipes are further pushed together.
3. Pipe joint is fully engaged when the female end of the outer pipe comes in contact (or is at least within 3/16" 5mm) to the base of the bead on the male end of the adjoining vent pipe.
4. When possible look within the pipe assembly to verify that no sign of seal gasket is showing. Complete the joint assembly by securing the joint using #8 x 1/2" sheet metal screws (3 per joint) at each pre-punched hole on the female end of each joint.

WARNING: SHEET METAL SCREWS ARE FOR DOUBLE WALL OUTER CASING ONLY. NEVER USE SCREWS, RIVETS OR OTHER FASTENERS TO PENETRATE THE INNER FLUE WALL.

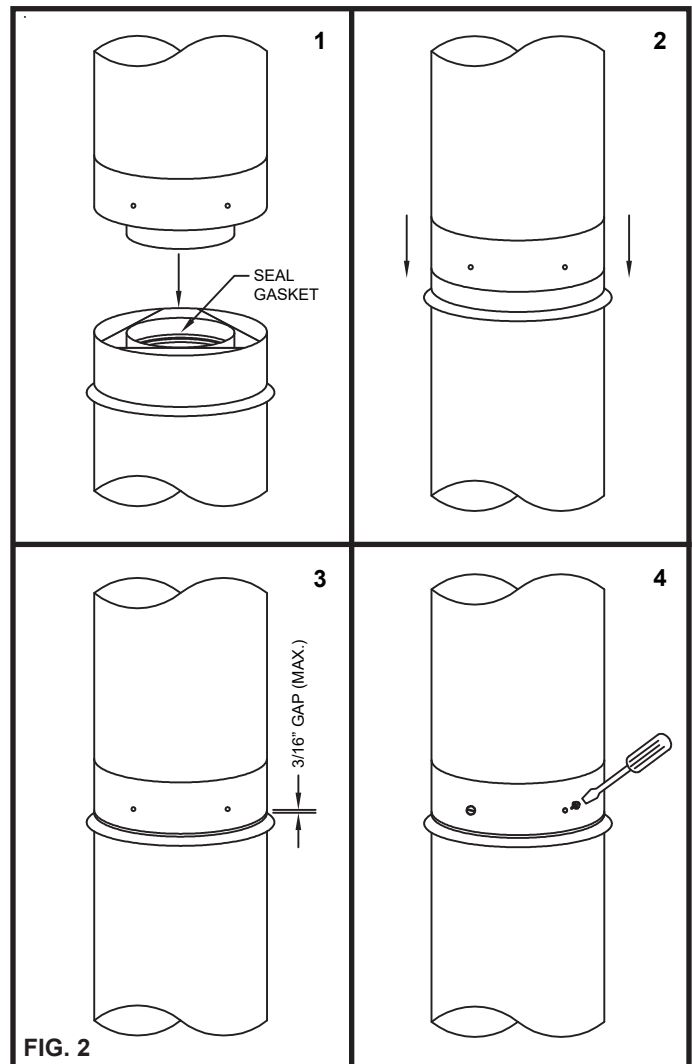

JOINT ASSEMBLY-LARGE DIAMETER

6"-36" (152mm-914mm) DIAMETER FCSSW, FCS, FCS-1 & FCS-2

Connection Tips For Sealant Applications (See FIG. 3):

The Corr/Guard (Model FCS and FCSSW) joint sealing system is designed for quick and easy installation:

NOTE: When assembling 6"-36" diameter Corr/Guard vent, always install the female flue end elevated above the male flue end. Change of directions are made by using a male to male or female to female adapter depending on the flow of the condensate.

1. Inspect flanged surfaces just prior to installation, and if contaminated with oil or dirt, clean with rubbing alcohol. Apply a continuous bead of P070 or P077 sealant in the corner of the sleeve and flange.
2. Join the two flanged ends of the pipe sections, compressing the P070 or P077 sealant just applied.
3. Fill the channel of Flange Band with P070 or P077 Sealant.
4. Install the flange band around the flanges and firmly tighten (Torque: 2 ft-lbs to 5 ft-lbs.). **DO NOT over tighten for risk of damage to joint. DO NOT locate the fasteners of the flange band on the bottom side of vent for horizontal installations.**

IMPORTANT: Allow P070 or P077 Sealant to cure 24 hours before operating appliances.

5. **(FCS-1 & FCS-2 INSTALLATIONS ONLY)** Pack the void between inner and outer walls with insulation strips.
6. Secure the outer casing with the casing closure band. Apply clear silicone sealant to closure band for exterior applications only.

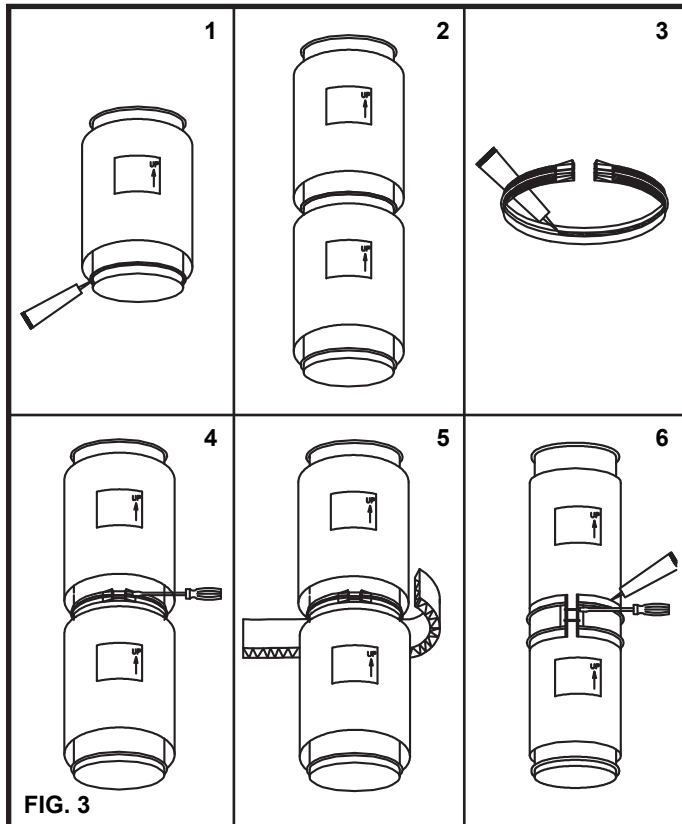
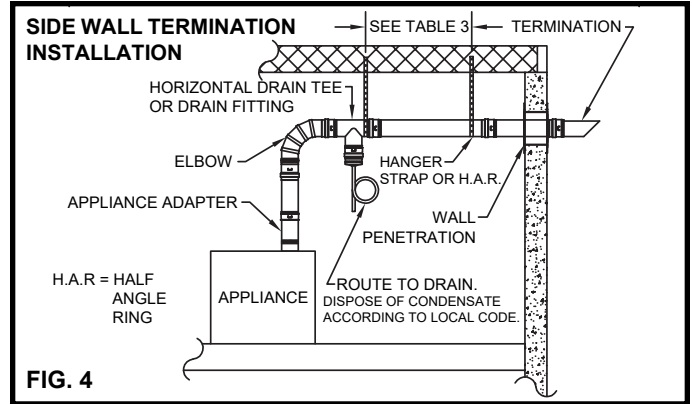

TABLE 3

SUPPORT	PIPE DIA./MODEL	DIST. BETWEEN SUPPORTS
HORIZONTAL RUNS (INCLUDING BETWEEN ELBOWS)	3"-5" (76mm-125mm) CG & CGSW	7' (2.13m)
	6"-24" (152mm-610mm) FCS & FCSSW	7' (2.13m)
	6"-24" (152mm-610mm) FCS-1	6' (1.83m)
	6"-24" (152mm-610mm) FCS-2	5' (1.52m)
	26"-36" (660mm-914mm) FCS & FCSSW	10'-6" (3.20m)
	26"-36" (660mm-914mm) FCS-1	10' (3.05m)
	26"-36" (660mm-914mm) FCS-2	9' (2.70m)



VERTICAL SUPPORTS

- Unless installed in a fire rated shaft, a fire stop / vertical support is required when penetrating floors and ceilings.
- Vertical supports are to be used after each transition to vertical. Refer to **TABLE 4** for support methods and heights.

TABLE 4

SUPPORT METHODS	PIPE DIAMETER / MODEL	MAXIMUM HEIGHT
PLATE SUPPORTS	3"-5" (76mm-125mm) CG/CGSW	30' (9.1m)
	6"-36" (660mm-914mm) FCS/FCSSW	100' (30.5m)
	6"-36" (660mm-914mm) FCS-1	85' (25.9m)
	6"-36" (660mm-914mm) FCS-2	75' (22.9m)
WALL BAND	6"-16" (152mm-406mm) FCS	8' (15.2m) INTERIOR
	6"-16" (152mm-406mm) FCS-1	7' (2.1m) INTERIOR
	6"-14" (152mm-406mm) FCS-2	6' (1.8m) INTERIOR
	6"-12" (152mm-305mm) FCSSW	8' (15.2m) INTERIOR
ROOF SUPPORTS (PLATE SUPPORT AT ROOF FOR FREE STANDING)	3" - 5" (76mm-125mm) CG/CGSW	5' (1.5m)
	6"-36" (660mm-914mm) FCS/FCSSW	10' (3.0m)
	6"-36" (660mm-914mm) FCS-1/FCS-2	10' (3.0m)
WALL SUPPORTS (GUIDE EVERY 10' (3.0M) FOR EXTERIOR)	3" - 5" (76mm-125mm) CG/CGSW	6' (1.8m) EXTERIOR
	3" - 5" (76mm-125mm) CG/CGSW	30' (9.1m) INTERIOR
	6"-24" (152mm-610mm) FCS/FCSSW	8' (2.4m) EXTERIOR
	6"-24" (152mm-610mm) FCS-1	8' (2.4m) EXTERIOR
	6"-22" (152mm-610mm) FCS-2	8' (2.4m) EXTERIOR
	6"-24" (152mm-610mm) FCS/FCSSW	30' (9.1m) INTERIOR
	6"-24" (152mm-610mm) FCS-1	25' (7.6m) INTERIOR
	6"-22" (152mm-610mm) FCS-2	22' (6.7m) INTERIOR
	26"-36" (660mm-914mm) FCS/FCSSW	40' (12.2m) INTERIOR
	26"-36" (660mm-914mm) FCS-1	34' (10.4m) INTERIOR
26"-36" (660mm-914mm) FCS-2	30' (9.1m) INTERIOR	
STACK SUPPORTS	6"-36" (660mm-914mm) FCS/FCSSW	100' (30.5m)
	6"-36" (660mm-914mm) FCS-1/FCS-2	100' (30.5m)

NOTE: Wall Hanger 3"-5" CG/CGSW alignment only, not a vertical support.

INSTALLATION

HORIZONTAL SUPPORTS

Use non-combustible hanger straps of Half Angle Rings (HAR). See **TABLE 3** to support the vent system from ceiling joints or other solid structures (see **FIG. 4**)

WARNING: DO NOT PUNCTURE VENT SYSTEM.

- Vent must not sag or dip, providing areas for condensate to collect.

Vertical vent systems can be suspended pre-assembled and lowered into a shaft. Refer to **TABLE 5** for maximum height that can be suspended from overhead. **Do not** pre-assemble in the horizontal position and raise to the vertical position for installation.

WARNING: ALL JOINTS MUST BE PROPERLY ASSEMBLED AND ALLOWED TO CURE BEFORE LIFTING FOR INSTALLATION.

TABLE 5

Diameter	Height			
	FCSSW	FCS	FCS-1	FCS-2
6"(152mm)	229'(70m)	75'(23m)	62'(19m)	55'(17m)
7"(178mm)	215'(66m)	70'(21m)	58'(18m)	52'(16m)
8"(203mm)	200'(61m)	70'(21m)	58'(18m)	52'(16m)
9"(229mm)	190'(58m)	60'(18m)	49'(15m)	44'(13m)
10"(254mm)	175'(53m)	60'(18m)	49'(15m)	44'(13m)
12"(305mm)	145'(44m)	50'(15m)	41'(15m)	37'(11m)
14"(356mm)	120'(37m)	50'(15m)	41'(15m)	37'(11m)
16"(406mm)	120'(37m)	50'(15m)	41'(15m)	37'(11m)
18"(105mm)	105'(32m)	45'(14m)	37'(11m)	33'(10m)
20"(508mm)	105'(32m)	45'(14m)	37'(11m)	33'(10m)
22"(559mm)	95'(29m)	40'(12m)	33'(10m)	30'(9m)
24"(610mm)	90'(27m)	40'(12m)	33'(10m)	30'(9m)
26"(660mm)	90'(27m)	50'(15m)	40'(12m)	40'(12m)
28"(711mm)	90'(27m)	40'(12m)	40'(12m)	30'(9m)
30"(762mm)	80'(24m)	40'(12m)	40'(12m)	30'(9m)
32"(813mm)	80'(24m)	40'(12m)	30'(9m)	30'(9m)
34"(864mm)	70'(21m)	40'(12m)	30'(9m)	30'(9m)
36"(914mm)	70'(21m)	30'(9m)	30'(9m)	30'(9m)

PLATE SUPPORT ASSEMBLY

The Plate Support Assembly is designed to provide support to vertical and horizontal sections. The Plate Support must be attached to the building structure or support with rigid structural members. Proper clearance to combustible construction must be maintained.

For maximum support, attach the entire perimeter of the Plate Support Assembly to the structural framing. (See **FIG. 5**). Structural members are supplied by the installer. The Flange Band is placed between the Support Plate and the Clamp Rings and aligned with notches for the Flange Band Clamps. Align holes of the support plate and Clamp Rings and assemble together using the hardware provided.

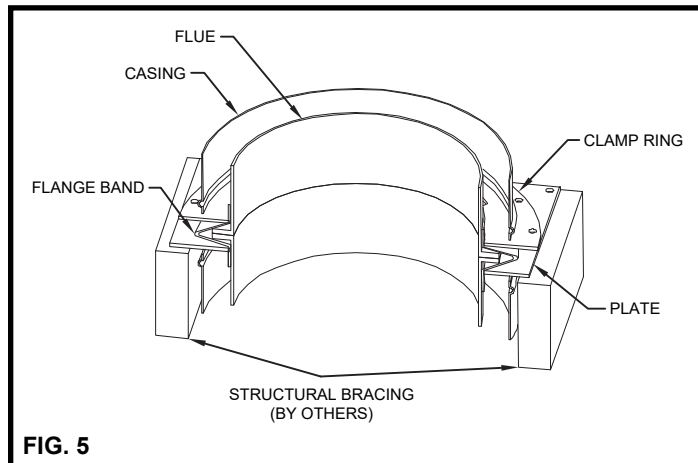

WALL PENETRATION

1. Prior to installation, determine proper location of wall thimble so that a minimum slope of 1/4" (6mm) per foot is maintained in the horizontal section of vent to ensure proper flow of condensation.
2. Prepare the wall by cutting a square opening per **TABLE 6**. (Opening size adequate to insert Wall Thimble components)
3. Install the Wall Thimble by inserting the larger of the two parts on the appliance (interior) side.

4. Next, apply a bead of sealant around the edges of the exterior (smaller of the two parts) Wall Thimble component. Then install this part of the Wall Thimble by inserting the smaller collar into the other component from the previous step.

NOTE: The two horizontal cylinders of the Thimble must engage a minimum of two inches.

5. Fasten both sides of the Wall Thimble using screws or nails.
6. Once the Thimble is installed, Corr/Guard vent pipe can be inserted into the Thimble. For 3" - 5" diameter Corr/Guard insert the male end first. (See **FIG. 6, 7 & 8**).
7. Assemble Corr/Guard vent from the Wall Thimble section back to the appliance.
8. Install a horizontal termination to complete the assembly.
9. Once assembly is completed, apply a bead of high-temp sealant around the pipe and the exterior plate of the Thimble to protect against weather.

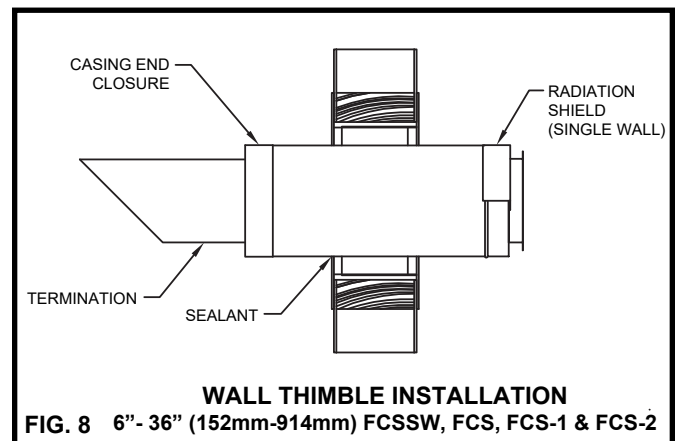
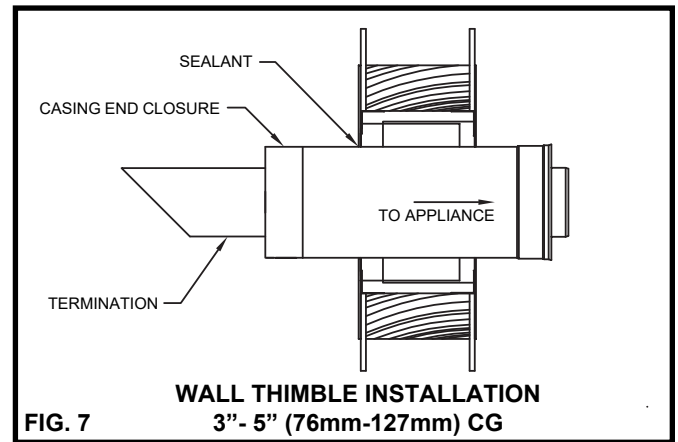
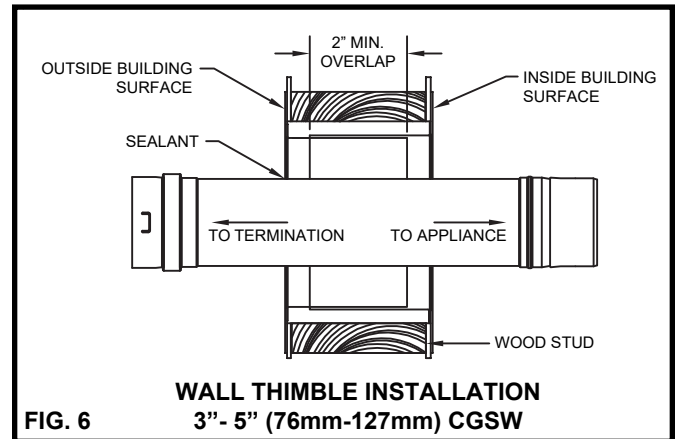

TABLE 6

PIPE DIAMETER	FRAMING DIMENSIONS (MINIMUM)
3"-5" (76mm-127mm) CGSW (SINGLE WALL)	(PIPE DIA.+5") x (PIPE DIA.+5") (PIPE DIA.+127mm) x (PIPE DIA.+127mm)
3"-5" (76mm-127mm) CG (DOUBLE WALL)	(PIPE DIA. + 5") X (PIPE DIA. + 5") (PIPE DIA.+127mm) x (PIPE DIA.+127mm)
6"-24" (152mm-610mm) FCSSW (SINGLE WALL)	(PIPE DIA. + 6") X (PIPE DIA. + 6") (PIPE DIA.+152mm) x (PIPE DIA.+152mm)
6"-24" (152mm-610mm) FCS & FCS-1 (DOUBLE WALL)	(PIPE DIA. + 6") X (PIPE DIA. + 6") (PIPE DIA.+152mm) x (PIPE DIA.+152mm)
6"-24" (152mm-610mm) FCS-2 (DOUBLE WALL)	(PIPE DIA. + 8") X (PIPE DIA. + 8") (PIPE DIA.+203mm) x (PIPE DIA.+203mm)
26"-36" (660mm-914mm) FCSSW (SINGLE WALL)	(PIPE DIA. + 8") X (PIPE DIA. + 8") (PIPE DIA.+203mm) x (PIPE DIA.+203mm)
26"-36" (660mm-914mm) FCS & FCS-1 (DOUBLE WALL)	(PIPE DIA. + 8") X (PIPE DIA. + 8") (PIPE DIA.+203mm) x (PIPE DIA.+203mm)
26"-36" (660mm-914mm) FCS-2 (DOUBLE WALL)	(PIPE DIA. + 10") X (PIPE DIA. + 10") (PIPE DIA.+254mm) x (PIPE DIA.+254mm)

HORIZONTAL TERMINATIONS

A venting system that exits through a side wall shall:

- Terminate not less than 12 inches (305 mm) above the ground.
- Be located above the snow line in geographical areas where snow accumulates.
- Not be located in traffic areas such as walkways unless the venting system is at least 7 feet (2.1 m) above the ground (See FIG. 9).

When an appliance incorporates a combustion air inlet system, the venting system shall terminate:

- 6 feet (1.8m) or more from the combustion air intake of any appliance.
- More than 3 feet (0.9m) from any other building opening, gas utility meter, service regulator or the like.
- Less distance is permitted if specified in the appliance's installation instructions.

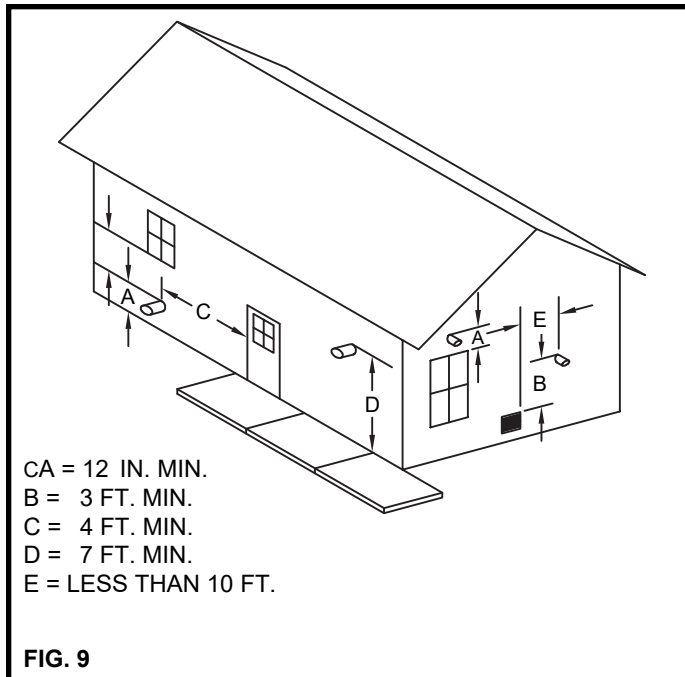

VERTICAL TERMINATIONS

- Enclose residential exterior vent systems below the roof line or use double wall Corr/Guard (CG/FCS/FCS-1/FCS-2) to limit condensation due to cool down of flue gases.
- The total equivalent length from the appliance outlet to the termination shall not exceed maximum length specified by the appliance manufacturer's installation instructions.
- Vertical terminations must terminate no less than 2' (0.61m) above the roof or any wall or vertical structure closer than 8' (2.4m). A vent cap or other equivalent termination is required to keep rain or debris out of the vent.

1. Starting at the appliance outlet, attach the first section or appliance adaptor. (See FIG. 10 & 11 for typical installation.)
2. Continue assembly of pipe until nearing a ceiling penetration. Locate and cut hole in floor and ceilings that will be penetrated. Hole size must maintain minimum listed clearances per TABLE 1.
3. Install a firestop support when penetrating the ceiling to support the vertical run of the vent system.
4. When installing a firestop in the attic, the firestop or support plate is located on top of the joist to prevent insulation from falling into the joist.
5. Continue with the vent penetrating the roof. At the roof, the opening must maintain a minimum of clearance to combustibles as specified in these instructions and on the labeled vent product.
6. Above the roof, a flashing and storm collar are required. Use high temperature sealant to seal the storm collar to the vent so that rain will not penetrate the roof opening (See FIG. 12, 13 & 14).

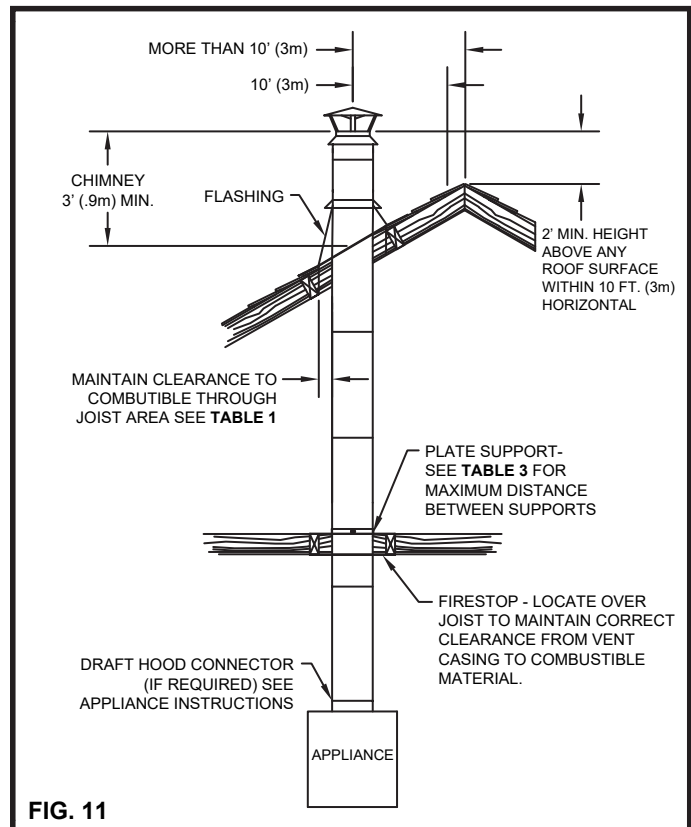
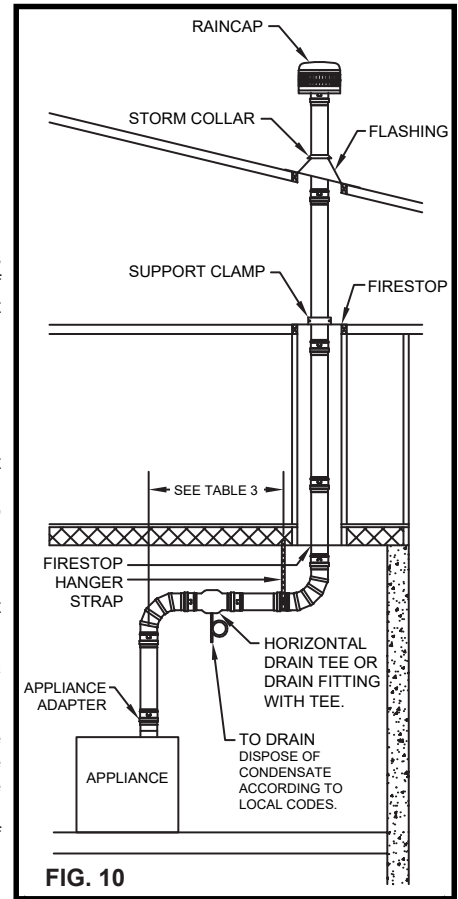

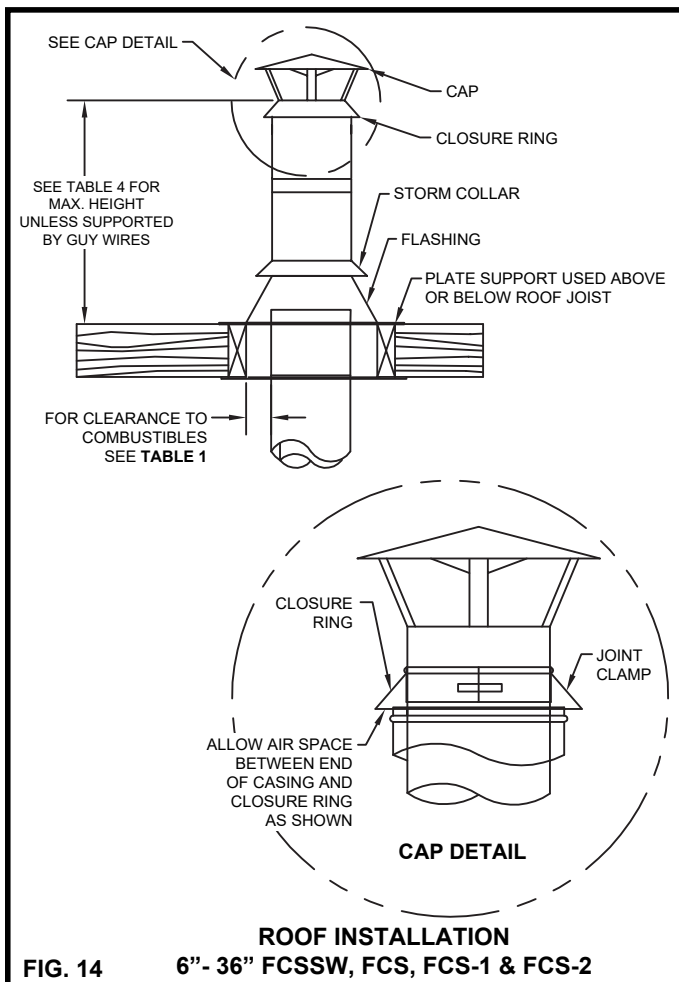
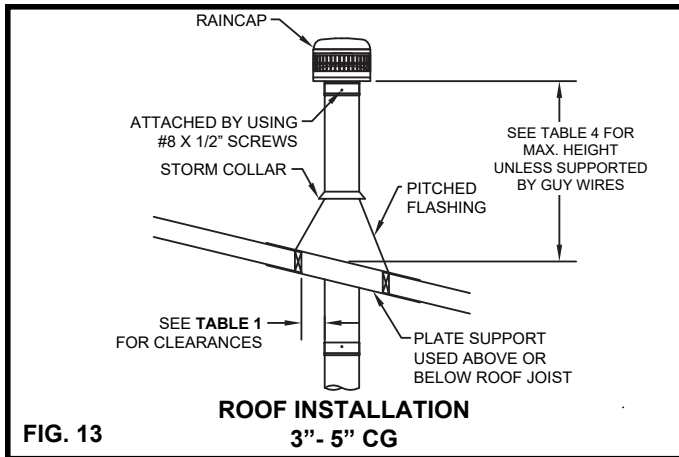
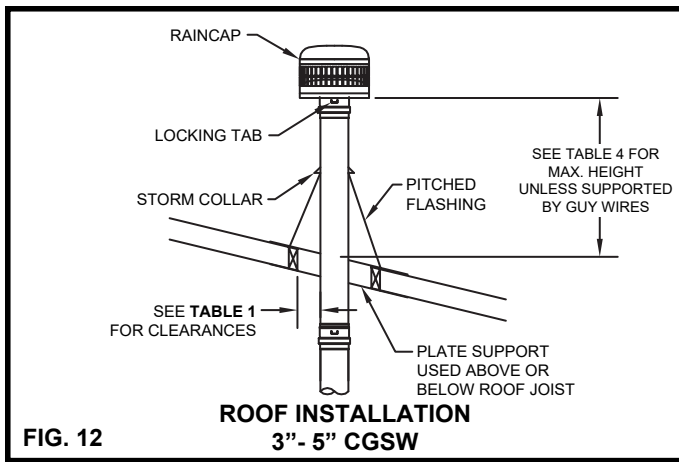

EXTERIOR INSTALLATION

Enclose exterior vent systems below the roof line or use double wall Corr/Guard (CG/FCS/FCS-1/FCS-2) to limit condensation due to cool down of flue gases.

1. There may be installations where Corr/Guard vent shall run vertically - exterior to the building and a wall band support is needed. A wall support (WS) is used to secure the vent system to a wall while maintaining the minimum clearance to combustible construction (See FIG. 15).
2. Wall supports must be securely fastened to a solid member of the building using appropriate fasteners for various building materials such as wood, steel siding or masonry.
3. Exterior mounted wall supports are to be vertically spaced per TABLE 4 on PAGE 4.
4. Wall supports are designed to be fastened to the vent by means of clamping externally to the vent for 3"-24" diameters. No screws are to puncture the vent wall.
5. When system is installed outdoors, the upper side (upper half of horizontal position) of the closure band bead should be sealed with clear silicone sealant to make the casing water tight.

WARNING: DONOTRIVETORSCREWSUPPORTSTOTHEVENT OR OTHERWISE PUNCTURE THE VENT WALL.

WARNING: DO NOT PLACE ANY TYPE OF INSULATION IN ANY REQUIRED CLEARANCE SPACES SURROUNDING THE VENT SYSTEM.

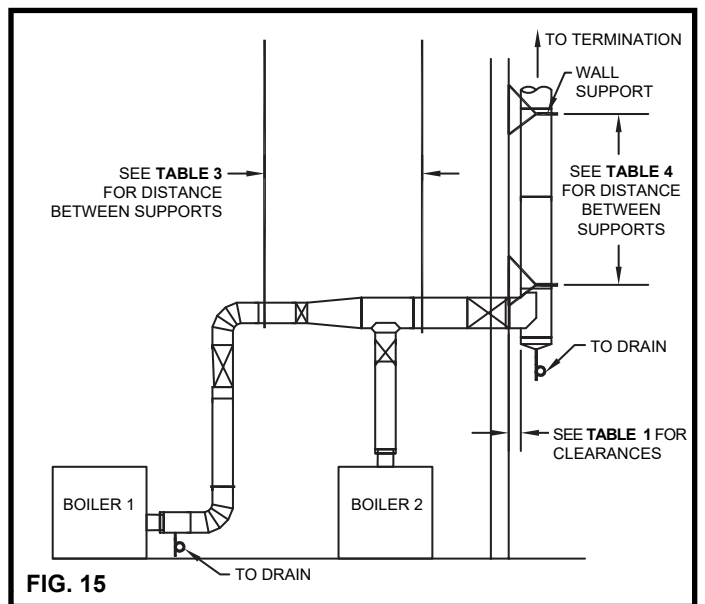

GUY RING (FCSGR)

Chimneys that exceed 5' above the roof, or are installed in severe weather regions, may require a guy ring (FCSGR) to enable the chimney to resist wind loads. The guy ring is connected to the building or other structure by means of cables or braces.

CONDENSATE REMOVAL

All sections of a ventilation system shall have a minimum upward slope of 1/4":12" for CAT II, CAT III and CAT IV appliances or downward slope for CAT III & CAT IV appliances. Condensate Drains must be provided at any low point within the venting system.

If an appliance does not supply a condensate drain and one is required per the appliance manufacturer's instructions or local codes, install a drain fitting in the horizontal conduit, as close as possible to the appliance vent collar.

WARNING: NEVER INSTALL A DRAIN IN A SYSTEM WITH AN APPLIANCE NOT INVESTIGATED FOR USE WITH A CONDENSATE DRAIN.

Sleeved Corr/Guard drain fittings contain a drain tube that should be located at the bottom of the vent or fitting when installed properly. A drain hose must be attached to the tube and a trap loop must be formed into the drain hose. The trap loop should be at least four times the appliance's rated stack pressure in inches of water column or sized for 15" (381mm) w.c. max. vent pressure, which ever is less (See FIG. 16).

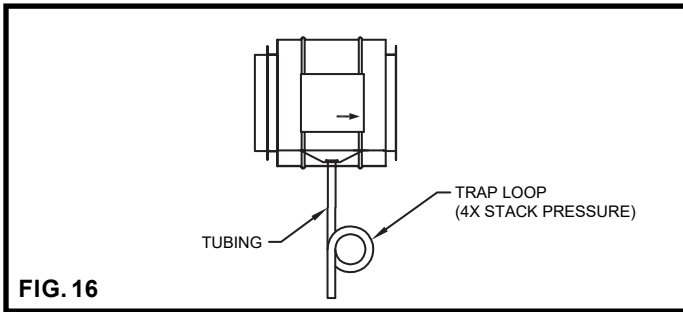

FIG. 16

VARIABLE LENGTH

For installations that require non-standard vent lengths, Corr/Guard Variable Length vent sections may be used. The vent section consists of an inner conduit that slip fits into the outer conduit, a compression band, or integral clamp and an outer casing (for double wall only).

3"- 5" (76mm-127mm) CG & CGSW

To install the VL vent section, first install the inner pipe section by connecting the male section to the adjoining double or single wall vent pipe. Insert male section until the bead of the joint stops at the edge of the female end of the vent section.

Next, expand the length of the inner pipe to the necessary length and tighten the integral clamping band using a hex drive or screw driver. The VL's are adjustable from 7 1/2" to 22" (191mm to 559mm). Continue with the next section of vent, making sure to fully join the inner pipe of the vent from the female end of the VL vent.

When installing double wall, finish the VL vent assembly by installing the outer casing wall around the VL inner pipe section. Secure the casing by installing #8x1/2" sheet metal screws at prepunched holes (See FIG. 17).

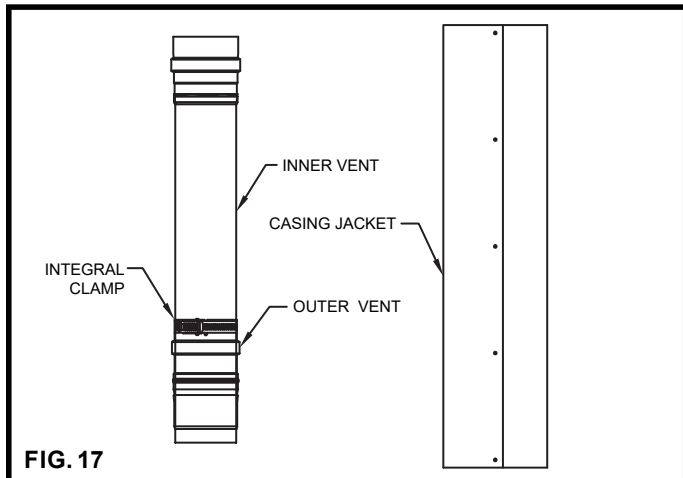

FIG. 17

6"- 36" (152mm-914mm) FCSSW, FCS, FCS-1 & FCS-2

To install the Variable Length, first apply a heavy bead of P070 or P077 sealant into the outer vent bead. Slide the inner vent into the outer vent. Locate the Variable Length into position and adjust to the proper length. Follow joint assembly details on PAGE 4. Apply a bead of P070 or P077 sealant at the joint of inner and outer vent and attach the compression band. The VL-22 is available for diameters 6"-36" (152mm-914mm). The VL-22 is adjustable from 9"-22" (228mm-559mm) for 6"-24" (152mm-610mm) diameters and 7"-22" (178mm-559mm) for 26"-36" (660mm-914mm) diameters. The VL-10 is available for diameters 26"-36" (660mm-914mm). The VL-10 is adjustable from 7"-10" (178mm-254mm). If the inner vent sleeve is too long to fit into adjacent vent component, trim back to fit. When installing double wall vent system, cut the outer jacket to fit between the mating vent and install using sheet metal screws (provided). (See FIG 18).

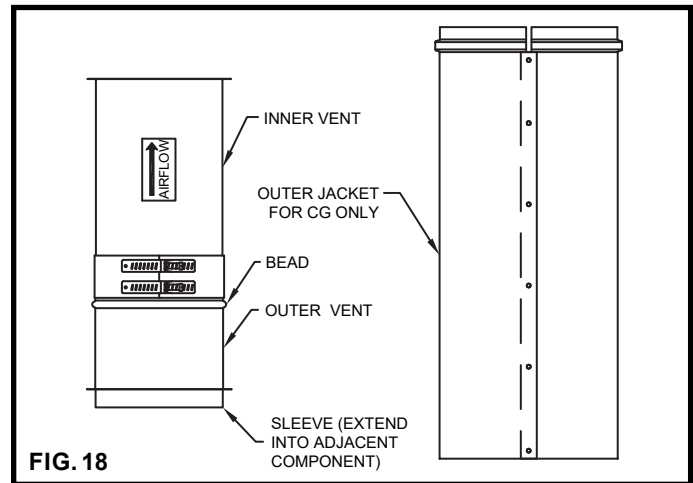

FIG. 18

MAINTENANCE INSTRUCTIONS

As with all vents, the Corr/Guard vent system should be inspected at least annually for the presence of deposits or debris and any accumulation should be removed. The vent system should also be inspected at regular periods for signs of leakage of condensate or combustion products at any joints.

If the vent system incorporates a drain hose from either an inline fitting or from a drain tee, the hose must be inspected periodically to ensure that water is in the trap loop. If a proper trap loop is not maintained, exhaust from the connected appliances may accumulate in the building area.

Where the duct is installed outside the building, the aluminized steel outer casing must be primed and painted. The painted surface should be maintained regularly to prevent possible deterioration of the casing surface. The use of stainless steel outer casing negates the need for painting.

IMPORTANT: The listing for this product is void if components other than those supplied as Listed Components by Metal-Fab, Inc. are used. All warranties, stated or implied, are void if this product and the appliances to which it is connected are not installed in accordance with their respective instructions and local code requirements.



P.O. Box 1138 • WICHITA, KANSAS 67201
(316)943-2351 • Fax (316)943-2717