

CEILING RADIATION DAMPER ASSEMBLY WITH BOOT AND COLLAR

TRUSS / GYPSUM INSTALLATION INSTRUCTIONS

MODEL MSCD-HC: RECTANGLE / ASSEMBLY FOR REGISTERS OR DROP DUCT
MODEL MRCD-HC: ROUND / ASSEMBLY FOR REGISTERS OR DROP DUCT

1-Hour Rated Register Grille Assembly CD/Plenum Box Assembly For
Floor/Ceiling, Roof/Ceiling and Wood Truss Assemblies

**UL DESIGN L528, L558, L562, L563, L574, L585,
P533, P544, P545, P547**

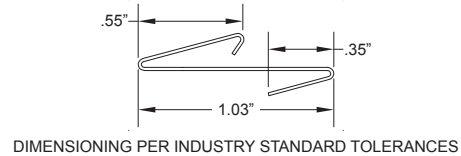
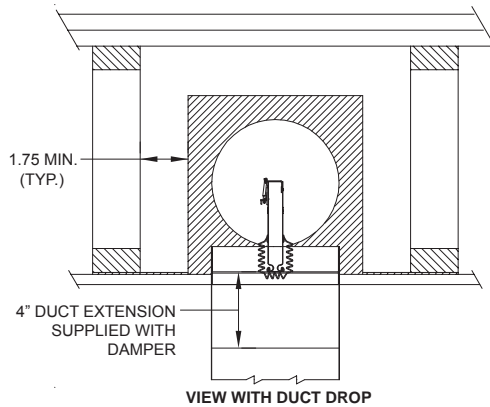
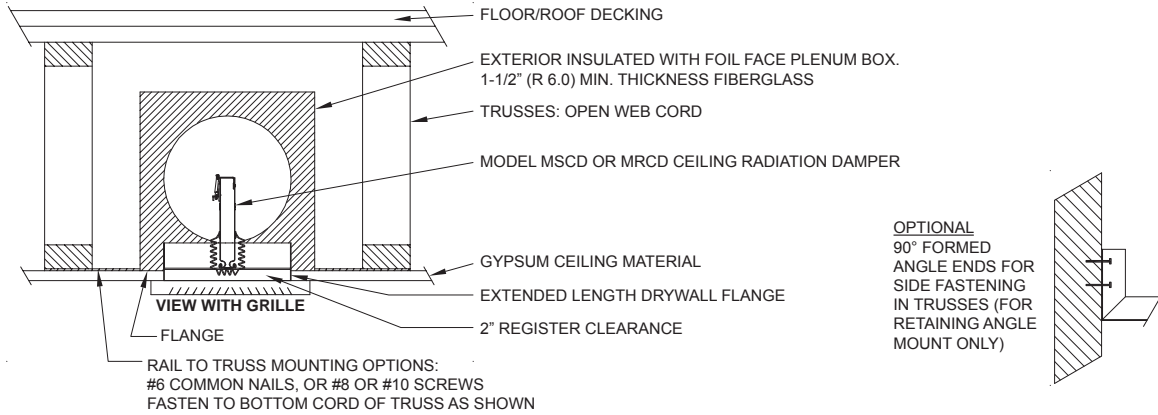

AS AN ALTERNATE TO HANGER ANGLES, TWO STANDARD
28 GA. MIN. BOOT RAILS SHOWN ABOVE ARE SNAPPED
ONTO OPPOSITE SIDES OF DAMPER BOX FLANGE
(SEE NOTES 2 & 4).

**NOTE: STEEL FRAMING MEMBERS SHALL BE INCLUDED
TO CREATE SPACE BETWEEN WOOD JOIST AND GYPSUM
BOARD CEILING TO ALLOW ROOM FOR BOOT RAILS
SHOWN ABOVE.**

Notes:

1. Before installing the damper assembly MSCD-HC and MRCD-HC, open the damper blades and hook the fusible link over the link catch on the opposite blade. Secure the wire link catch through the fuse link hole and carefully remove hand pressure that holds the damper blades together. The fuse link and wire catch will keep the damper blades open.
2. Measure the actual truss centers and add approx. 6" to determine the straight rail lengths, (2) required per box.
For Angle Mount Only: When using the optional formed Boot Rail, allow for adequate flange length at each mounting and span the truss cavity to overlap face of truss bottom cords a minimum of 2-1/2 inches.
3. Establish the location of the gypsum flange and snap the (2) hanger rails to the plenum box.
4. Mounting rails are fastened to trusses with a minimum of two fasteners for each mounting point using #6 common nails or #8 or #10 wood screws.
5. The clearance between each side of the ceiling damper and the duct drop shall be 1/16 inch for a total of 1/8 inch maximum.
6. Steel grille to be attached to the ceiling damper using #8 by 2 inch long sheet metal screws at each end fo the grille for a total of 2 (min.) screws.
7. Ceiling opening must be no larger than the inlet opening of the damper.
8. For fiberglass ductboard plenum box construction. See installation instructions L2866.

IMPORTANT: FASTENERS MUST NOT INTERFERE WITH THE DAMPER BLADE'S OPERATION



P.O. Box 1138 • WICHITA, KANSAS 67201
(316) 943-2351 • 1-800-835-2830
FAX (316) 943-2717

info@metal-fabinc.com • www.metal-fabinc.com