

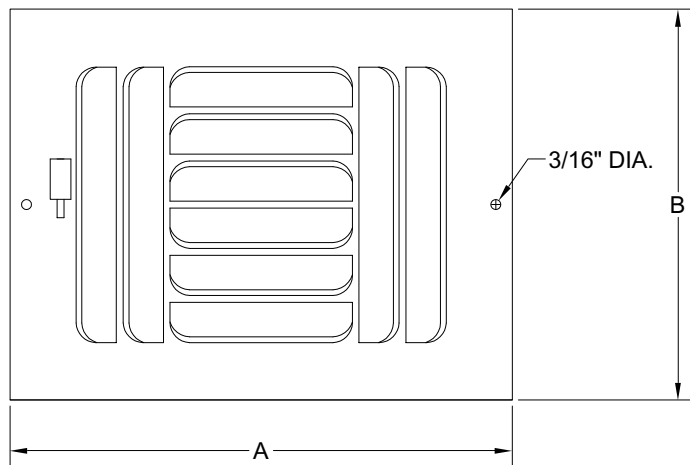

4 - WAY CURVED SIDEWALL/CEILING REGISTER SPECIFICATION CHART

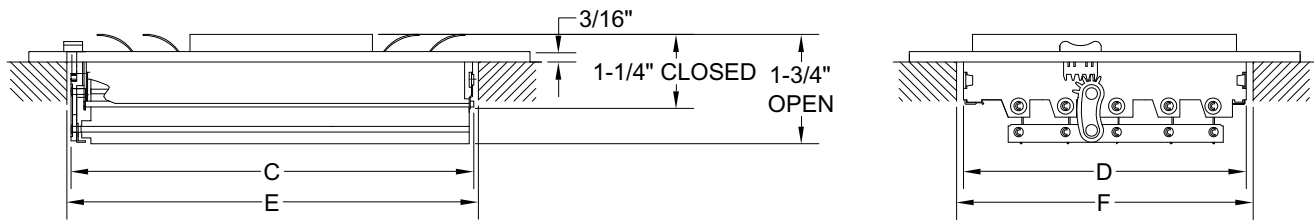

- Heavy Gauge Steel Construction
- Integral Multi-Shutter Damper
- Curved Blades
- 4-Way Deflection & Air Pattern
- Finish: White

Curved Sidewall/Ceiling Register 4-Way Dimensional Chart

Size (ExF)	Dimensions (See Detail Sketches)				Size (ExF)	Dimensions (See Detail Sketches)			
	A	B	C	D		A	B	C	D
6x6	7-3/4	7-3/4	5-7/8	5-5/8	12x12	13-3/4	13-3/4	11-7/8	11-5/8
8x8	9-3/4	9-3/4	7-7/8	7-5/8	14x14	15-3/4	15-3/4	13-7/8	13-5/8
10x10	11-3/4	11-3/4	9-7/8	9-5/8					

Curved Sidewall/Ceiling Register 4-Way

Face Velocity		300	400	500	600	700	800	900	1000
6x6 Ak=0.17	cfm	50	65	85	100	115	135	150	165
	Ps	0.036	0.068	0.108	0.156	0.204	0.284	0.344	0.440
	Throw	4/5	5/6	6/7	7/8	8/9	8/10	9/11	10/12
8x8 Ak=0.23	cfm	65	90	110	130	155	175	200	220
	Ps	0.020	0.044	0.068	0.092	0.128	0.164	0.212	0.264
	Throw	5/5	6/6	7/8	8/9	10/11	11/12	12/14	13/15
10x10 Ak=0.30	cfm	85	115	145	170	200	230	255	285
	Ps	0.016	0.028	0.048	0.064	0.088	0.116	0.148	0.180
	Throw	5/5	6/7	8/9	9/10	11/12	12/13	14/15	15/17
12x12 Ak=0.41	cfm	120	160	205	245	285	325	365	405
	Ps	0.016	0.024	0.032	0.048	0.068	0.084	0.108	0.132
	Throw	5/6	7/8	9/10	11/12	12/14	14/16	16/18	18/20
14x14 Ak=0.49	cfm	145	195	240	290	340	385	435	485
	Ps	0.008	0.016	0.028	0.040	0.048	0.064	0.080	0.104
	Throw	6/6	8/9	10/11	12/13	14/15	15/17	17/18	19/21

Terminal velocity of 75 fpm, Ps (in. H₂O) & Throw (ft)

