

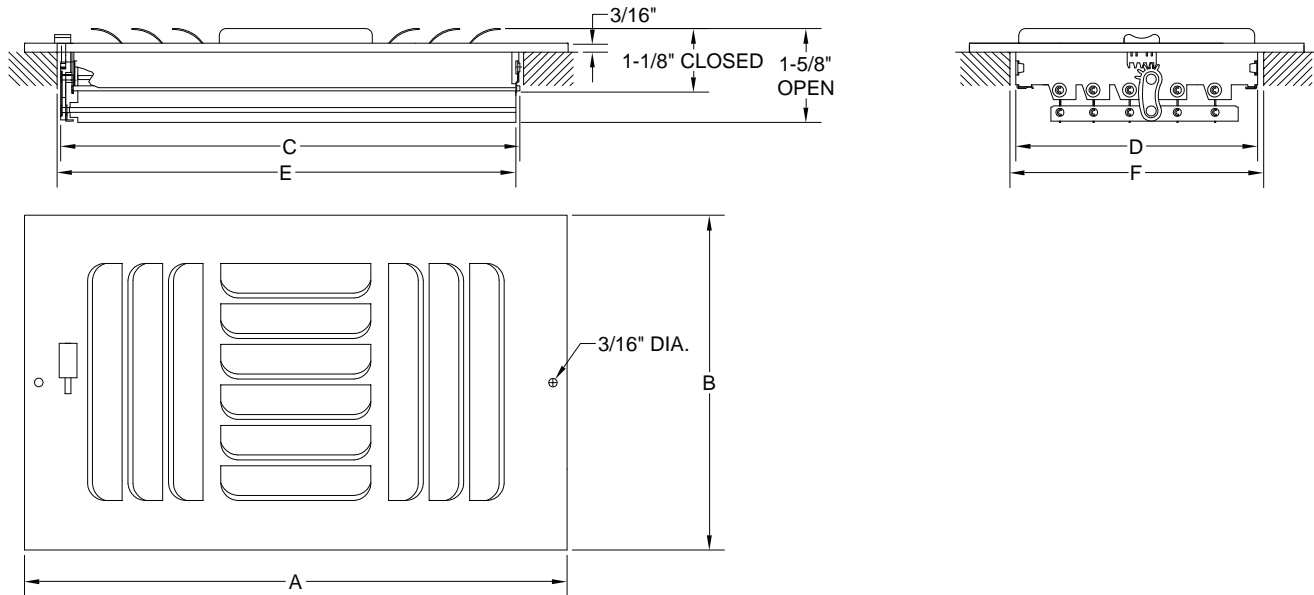

3 - WAY CURVED SIDEWALL/CEILING REGISTER SPECIFICATION CHART



- Heavy Gauge Steel Construction
- Integral Multi-Shutter Damper
- Curved Blades
- 3-Way Deflection & Air Pattern
- Finish: White

Curved Sidewall/Ceiling Register 3-Way Dimensional Chart

Size (ExF)	Dimensions (See Detail Sketches)				Size (ExF)	Dimensions (See Detail Sketches)			
	A	B	C	D		A	B	C	D
6x6	7-3/4	7-3/4	5-7/8	5-5/8	10x10	11-3/4	11-3/4	9-7/8	9-5/8
8x4	9-3/4	5-3/4	7-7/8	3-5/8	12x6	13-3/4	7-3/4	11-7/8	5-5/8
8x6	9-3/4	7-3/4	7-7/8	5-5/8	12x8	13-3/4	9-3/4	11-7/8	7-5/8
8x8	9-3/4	9-3/4	7-7/8	7-5/8	12x12	13-3/4	13-3/4	11-7/8	11-5/8
10x6	11-3/4	7-3/4	9-7/8	5-5/8	14x6	15-3/4	7-3/4	13-7/8	5-5/8
10x8	11-3/4	9-3/4	9-7/8	7-5/8	14x8	15-3/4	9-3/4	13-7/8	7-5/8

3-way Curved Sidewall/Ceiling Register

Face Velocity		300	400	500	600	700	800	900	1000
6x6 Ak =0.15	cfm	36	50	60	70	85	95	110	120
	Ps	0.016	0.032	0.044	0.060	0.080	0.104	0.128	0.164
	Throw L/S	6/4	8/5	9/6	10/7	12/8	15/9	17/11	20/12
8x4 Ak=0.12	cfm	35	45	60	70	80	90	105	115
	Ps	0.012	0.024	0.040	0.056	0.076	0.104	0.124	0.164
	Throw L/S	5/4	7/5	9/6	11/7	12/8	14/9	16/10	17/11
8x6 Ak=0.17	cfm	42	55	70	85	100	115	125	140
	Ps	0.020	0.032	0.048	0.064	0.084	0.108	0.136	0.168
	Throw L/S	6/3	8/4	10/6	12/7	14/8	17/9	18/11	21/12
8x8 Ak=0.21	cfm	55	75	95	115	130	150	170	190
	Ps	0.012	0.024	0.032	0.052	0.068	0.088	0.112	0.136
	Throw L/S	7/4	9/6	11/7	13/9	16/10	18/11	20/12	22/13
10x6 Ak .18	cfm	55	70	90	105	125	140	160	175
	Ps	0.012	0.024	0.040	0.060	0.080	0.104	0.136	0.168
	Throw L/S	8/4	9/5	11/7	13/8	15/9	18/10	19/11	22/13
10x8 Ak .25	cfm	65	90	110	130	155	175	200	220
	Ps	0.012	0.028	0.040	0.056	0.068	0.092	0.112	0.144
	Throw L/S	7/4	9/6	11/8	14/9	17/11	20/13	23/15	26/17
10x10 Ak .34	cfm	95	130	160	190	225	255	290	320
	Ps	0.016	0.028	0.044	0.060	0.088	0.120	0.140	0.176
	Throw L/S	8/5	11/7	14/8	17/10	20/12	23/14	26/16	28/18
12x6 Ak .24	cfm	65	90	110	130	155	175	200	220
	Ps	0.012	0.024	0.036	0.044	0.068	0.084	0.108	0.132
	Throw L/S	8/4	10/6	12/7	14/9	17/10	19/12	21/13	23/14
12x8 Ak .29	cfm	85	115	140	170	200	225	250	280
	Ps	0.008	0.020	0.028	0.040	0.048	0.064	0.080	0.096
	Throw L/S	9/5	12/7	15/9	17/11	19/13	21/15	24/17	28/19
12x12 Ak .40	cfm	115	155	195	235	275	310	350	390
	Ps	0.008	0.016	0.024	0.032	0.044	0.056	0.075	0.092
	Throw L/S	9/6	13/8	15/10	18/11	22/13	25/15	29/17	32/18
14x6 Ak .23	cfm	65	85	105	125	145	170	190	210
	Ps	0.008	0.016	0.028	0.036	0.052	0.068	0.088	0.104
	Throw L/S	8/4	10/6	12/7	15/9	17/10	19/11	21/13	23/14
14x8 Ak .34	cfm	90	120	150	180	210	240	270	300
	Ps	0.008	0.020	0.028	0.040	0.048	0.068	0.084	0.104
	Throw L/S	8/5	11/7	14/9	17/11	20/13	24/15	27/17	30/19

Terminal velocity of 75 fpm, Ps (in. H₂O) & Throw (ft)