

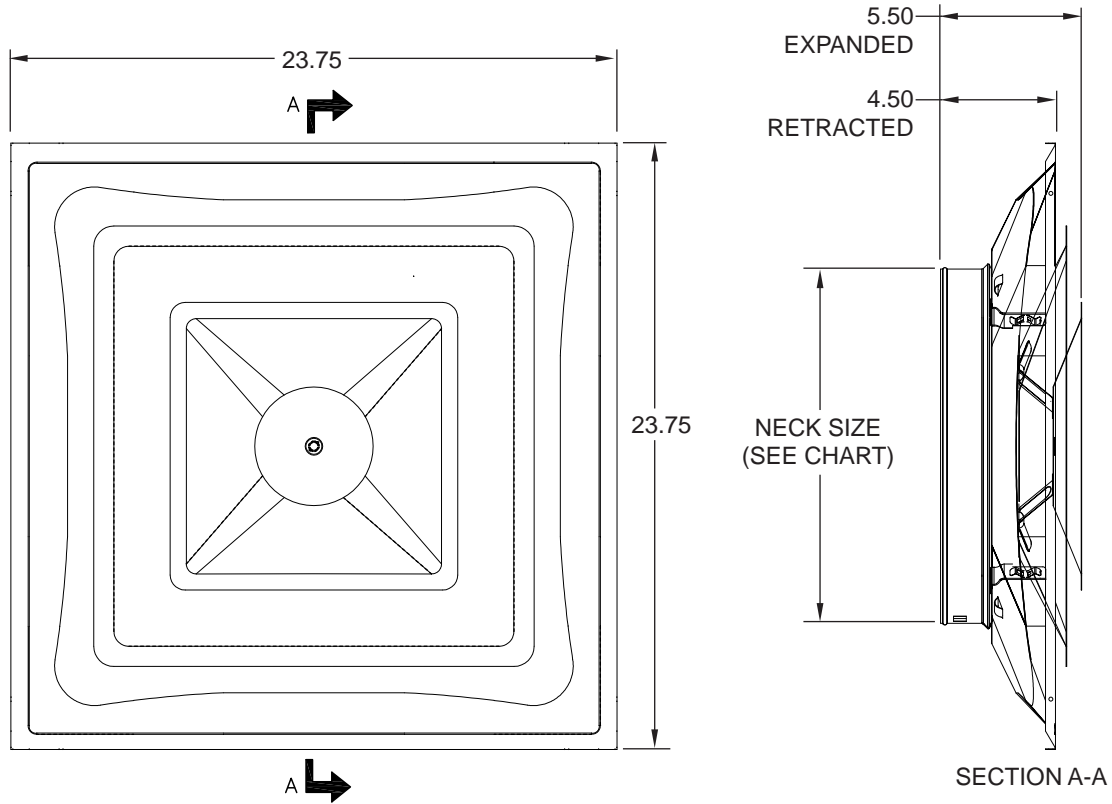

L2C & L2CI 2 CONE LIGHT COMMERCIAL CEILING DIFFUSER



- Heavy Gauge Steel Construction
- High Air Volume 2 Cone Design
- 360 deg. Uniform Air Diffusion
- Unique Retractable Cone Design for Flush Applications
- Fixed 2" High Collar for Easy Connectability
- Optional Butterfly Damper (MFLCBD Series)
- Damper Adjustable Through Face
- Optional Insulated Back (L2CI Series)
- White Finish

L2C & L2CI (Cones Fully Extended)

Neck Size (Dia)		Neck Velocity									
		400	500	600	700	800	900	1000	1200	1400	1600
6"	cfm	80	100	120	140	160	180	200	240	280	320
	An .20 Ps	0.008	0.016	0.024	0.032	0.048	0.060	0.076	0.116	0.156	0.208
	Ak .80 Throw	4.0	4.0	5.0	6.0	7.0	9.0	11.0	13.0	15.0	17.0
8"	cfm	140	175	210	245	280	315	350	420	490	560
	An .35 Ps	0.016	0.024	0.036	0.048	0.072	0.092	0.108	0.160	0.208	0.312
	Ak .92 Throw	5.0	6.0	8.0	9.0	10.0	12.0	13.0	16.0	19.0	21.0
10"	cfm	220	270	325	380	435	490	540	650	760	865
	An .54 Ps	0.028	0.044	0.060	0.076	0.104	0.136	0.168	0.224	0.284	0.460
	Ak 1.20 Throw	6.0	8.0	9.0	11.0	13.0	15.0	17.0	21.0	25.0	27.0
12"	cfm	315	390	470	550	625	705	780	940	1095	1250
	An .79 Ps	0.040	0.060	0.088	0.112	0.136	0.176	0.212	0.308	0.416	0.528
	Ak 1.65 Throw	7.0	8.0	11.0	13.0	15.0	16.0	18.0	22.0	26.0	30.0
14"	cfm	430	535	640	750	855	965	1070	1285	1500	1710
	An 1.07 Ps	0.064	0.084	0.116	0.136	0.180	0.212	0.300	0.408	0.524	0.696
	Ak 2.09 Throw	10.0	11.0	13.0	15.0	17.0	19.0	22.0	26.0	29.0	32.0

Terminal velocity of 75 fpm

L2C & L2CI (Cones Fully Retracted)

Neck Size (Dia)		Neck Velocity									
		400	500	600	700	800	900	1000	1200	1400	1600
6"	cfm	80	100	120	140	160	180	200	240	280	320
	An .20 Ps	0.024	0.040	0.056	0.072	0.100	0.116	0.144	0.204	0.284	0.360
	Ak .76 Throw	3.0	4.0	5.0	6.0	6.0	8.0	10.0	12.0	13.0	15.0
8"	cfm	140	175	210	245	280	315	350	420	490	560
	An .35 Ps	0.028	0.044	0.064	0.088	0.120	0.152	0.188	0.272	0.384	0.480
	Ak .88 Throw	5.0	6.0	7.0	8.0	9.0	10.0	12.0	14.0	16.0	18.0
10"	cfm	220	270	325	380	435	490	540	650	760	865
	An .54 Ps	0.044	0.068	0.096	0.128	0.156	0.200	0.256	0.368	0.500	0.640
	Ak 1.16 Throw	6.0	7.0	9.0	10.0	12.0	13.0	15.0	17.0	20.0	23.0
12"	cfm	315	390	470	550	625	705	780	940	1095	1250
	An .79 Ps	0.056	0.084	0.124	0.168	0.220	0.268	0.332	0.476	0.648	0.808
	Ak 1.61 Throw	6.0	9.0	11.0	12.0	14.0	15.0	17.0	20.0	22.0	25.0
14"	cfm	430	535	640	750	855	965	1070	1285	1500	1710
	An 1.07 Ps	0.080	0.128	0.172	0.228	0.276	0.340	0.464	0.644	0.812	1.004
	Ak 2.03 Throw	8.0	9.0	12.0	13.0	15.0	16.0	18.0	22.0	25.0	28.0

Terminal velocity of 75 fpm



P.O. Box 1138 • WICHITA, KANSAS 67201
 PHONE: 316-943-2351 • 800-835-2830
 FAX (316) 943-2717
 info@metal-fabinc.com
 www.metal-fabinc.com