



## INSTALLATION AND MAINTENANCE INSTRUCTIONS FOR SINGLE WALL BLACK PIPE

### GENERAL:

The Single Wall Black Pipe (SW) has been designed as the connector between the stove and a listed chimney system, such as Metal-Fab's Model TG chimney system which is UL listed for 2100° F. The SW pipe has been designed with a slip fit secured with sheet metal screws.

### SAFETY:

The SW pipe requires 18 inch clearance to combustible material. The SW pipe is not designed to be enclosed, nor is it to penetrate combustible floors or ceilings. There are many different appliance flue collars. The stove top adapter (SWA-1) may be required to fit into the appliance flue collar if the pipe will not fit inside the collar. Wood fuels create creosote during low firing which can be dangerous if allowed to accumulate in any portion of the SW connector or chimney system. The SW and chimney system should be periodically inspected for creosote and cleaned if necessary.

### INSTALLATION:

1. Determine the appliance outlet location relative to the chimney system ceiling support or existing masonry chimney. If the appliance is being terminated into an existing masonry chimney, the trim collar (SWTC) is used to close the gap between the brick and SW connector (See **FIG. 1**).
2. If your installation is using the slip connector (SW14S), the SW14S is attached to the ceiling support flue and secured with sheet metal screws (See **FIG. 2**).
3. Install the Stove Top Adapter (SWA-1) on the appliance collar with the crimp end into the appliance collar; if needed. Secure with sheet metal screws (See **FIG. 2**).
4. If more than 2 sections are used in your installation, install SW sections starting at the SWA-1 until only 2 sections are left to be installed. Install one SW section over the SW14S and adjust upward. Install the final SW section. Slide the upper most SW section downward to complete the connection. Secure each joint with sheet metal screws.
5. If elbows are required, only one pipe section is recommended between elbows (See **FIG. 3**). The elbows are secured to the pipe section with sheet metal screws.

**NOTE:** The 90 degree elbow (SW90) is normally used only to vent a top opening stove into an existing masonry chimney.

6. For rear outlet stoves, the Tee (SWT) is used to direct the exhaust upward. The SWA-1 is required between the stove outlet and the SWT (See **FIG. 4**).
7. For normal room heights, the telescoping sections (SWTL48 or SWTL66) can be used between the stove outlet and the ceiling support. Remove telescoping pipe sections and package of 3 ea. black screws from carton. Telescoping pipe sections are identified as top section having 3 holes at one end and bottom section having label located at one end. Slide top section into bottom section leaving 3 holes exposed on top and label located on the bottom (See **FIG. 5**). Slide the top section (with 3 holes up) down into the bottom section. Adjust pipe section a couple inches smaller than the measured gap being filled. Place the bottom section into the stove top adaptor SWA-1; if needed. Extend the SWTL48 or SWTL66 top section into the mating pipe section and secure with the 3 black screws supplied.

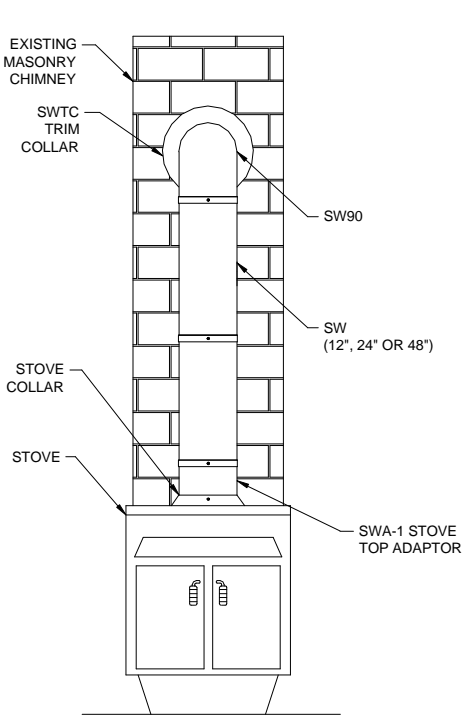
**NOTE:** The SW14S is not used with the telescoping sections.

8. If the stove outlet is a smaller diameter than the ceiling support, the single wall increaser can be used (SWI-8). The increaser normally secures to the ceiling support.
9. Upon installing the stovepipe, it is understood that blemishes or scratches can result that will require a touch up application of black paint. We recommend STOVE BRIGHT® #1990 Satin Black which comes in a 12 oz. spray can. When properly applied, this product is very effective in blending to the base coat of paint in both texture and color.

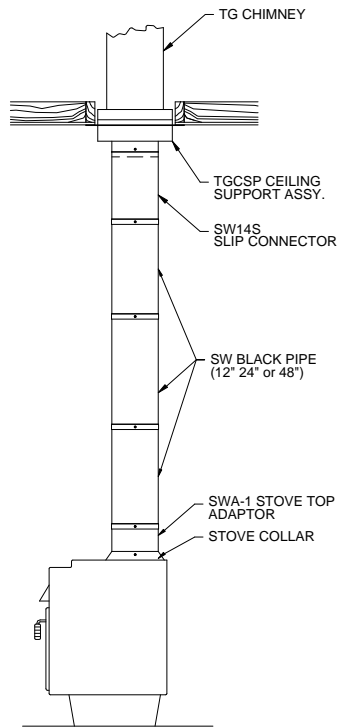
**NOTE:** If the spray can nozzle is located too close to the target surface, undesirable results may occur such as; running, too thick of a coat which will not blend, bubbling, or droplets of paint.

**MAINTENANCE:**

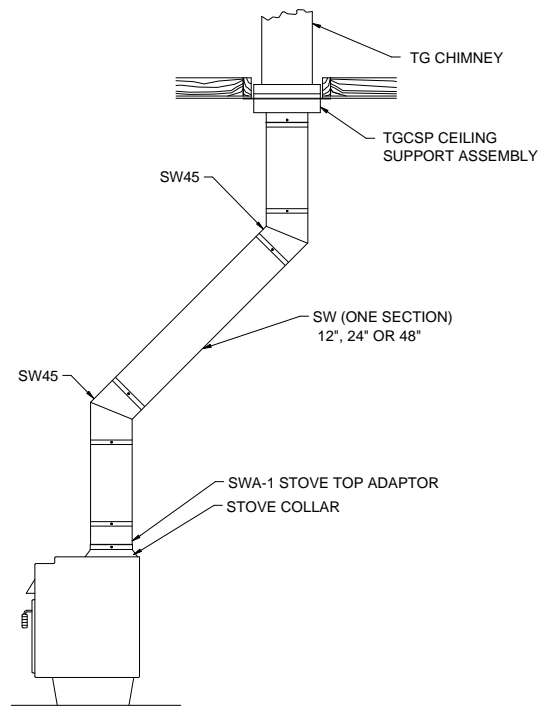
The Single Wall Black Pipe and the listed chimney system should be inspected for creosote buildup periodically during the heating season, and cleaned if necessary. Inspect the Single Wall Black Pipe for any damage before the start of the season. Replace any damaged parts. The satin black paint may be touched-up, as required, with STOVE BRIGHT® #1990.



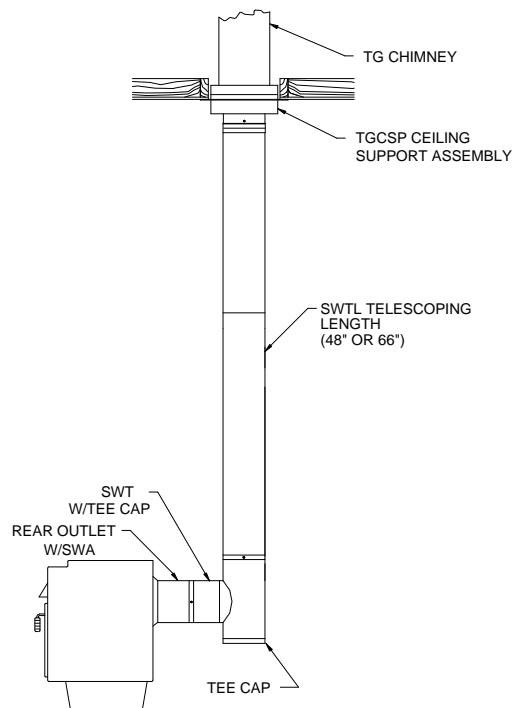
**FIG. 1**



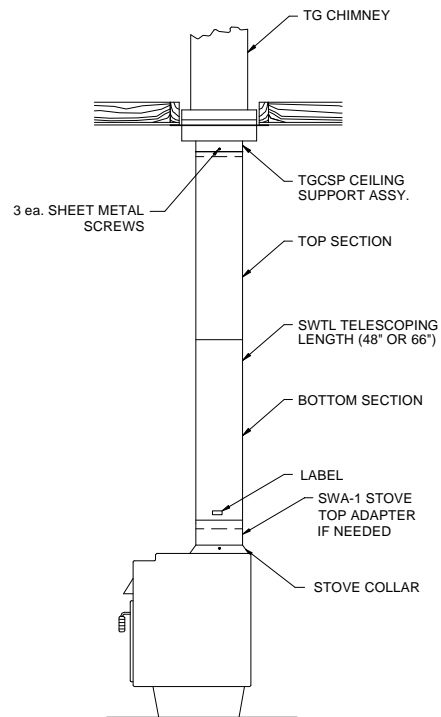
**FIG. 2**



**FIG. 3**

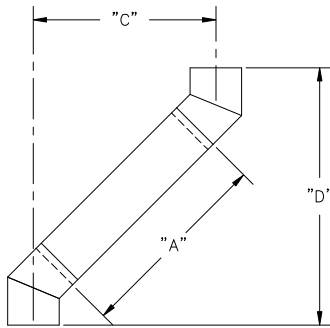


**FIG. 4**



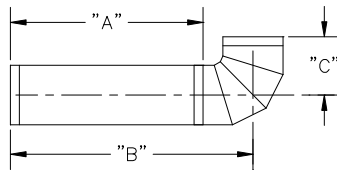
**FIG. 5**

**SINGLE WALL BLACK PIPE OFFSET CHART  
45° ELBOW VERTICAL TO HORIZONTAL TO VERTICAL**



"A"	ASSEMBLED PIPE LENGTHS	PIPE DIA.			
		6" DIA.		8" DIA.	
		"C"	"D"	"C"	"D"
0	NO PIPE	6 1/4	16	6 1/4	15 3/4
12	12"	14 1/2	24	14 1/4	23 3/4
24	24"	22 3/4	32 1/2	22 3/4	32 1/4
36	12" & 24"	30 3/4	41	31 1/4	40 3/4
48	(2) 24"	39 3/4	49 1/2	39 1/2	49
60	48" & 12"	48 1/4	58	48	57 1/2
72	48" & 24"	56 3/4	66 1/2	56 1/2	66
84	48", 24" & 12"	65 1/4	74 3/4	65	74 1/2
96	(2) 48"	73 1/2	83 1/4	73 1/2	83
108	(2) 48" & 12"	82 1/4	91 3/4	82	91 1/2
120	(2) 48" & 24"	90 1/2	100 1/4	90 1/2	100

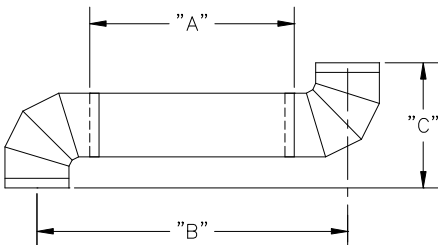
**SINGLE WALL BLACK PIPE OFFSET CHART  
90° ELBOW HORIZONTAL TO VERTICAL**



"A"	ASSEMBLED PIPE LENGTHS	PIPE DIA.					
		6" DIA.		7" DIA.		8" DIA.	
		"B"	"C"	"B"	"C"	"B"	"C"
0	NO PIPE	6 3/4	7 1/4	7 7/8	8 3/8	7 3/4	8 3/8
12	12"	18 3/4	7 1/4	19 7/8	8 3/8	19 3/4	8 3/8
24	24"	30 3/4	7 1/4	31 7/8	8 3/8	31 3/4	8 3/8
36	12" & 24"	42 3/4	7 1/4	43 7/8	8 3/8	43 3/4	8 3/8
48	(2) 24"	54 3/4	7 1/4	55 7/8	8 3/8	55 3/4	8 3/8
60	48" & 12"	66 3/4	7 1/4	67 7/8	8 3/8	67 3/4	8 3/8
72	48" & 24"	78 3/4	7 1/4	79 7/8	8 3/8	79 3/4	8 3/8
84	48", 24" & 12"*	90 3/4	7 1/4	91 7/8	8 3/8	91 3/4	8 3/8
96	(2) 48"*	102 3/4	7 1/4	103 7/8	8 3/8	103 3/4	8 3/8
108	(2) 48" & 12"*	114 3/4	7 1/4	115 7/8	8 3/8	115 3/4	8 3/8
120	(2) 48" & 24"*	126 3/4	7 1/4	127 7/8	8 3/8	127 3/4	8 3/8

\*48" LENGTHS NOT AVAILABLE IN 7" DIA.

**SINGLE WALL BLACK PIPE OFFSET CHART  
90° ELBOW VERTICAL TO HORIZONTAL TO VERTICAL**



"A"	ASSEMBLED PIPE LENGTHS	PIPE DIA.					
		6" DIA.		7" DIA.		8" DIA.	
		"B"	"C"	"B"	"C"	"B"	"C"
0	NO PIPE	13 1/2	14 1/2	16 3/8	16 1/2	15 1/16	16 1/16
12	12"	25 1/2	14 1/2	28 3/8	16 1/2	27 1/16	16 1/16
24	24"	37 1/2	14 1/2	40 3/8	16 1/2	39 1/16	16 1/16
36	12" & 24"	49 1/2	14 1/2	52 3/8	16 1/2	51 1/16	16 1/16
48	(2) 24"	61 1/2	14 1/2	64 3/8	16 1/2	63 1/16	16 1/16
60	48" & 12"*	73 1/2	14 1/2	76 3/8	16 1/2	75 1/16	16 1/16
72	48" & 24"*	85 1/2	14 1/2	88 3/8	16 1/2	87 1/16	16 1/16
84	48" 24" & 12"*	97 1/2	14 1/2	100 3/8	16 1/2	99 1/16	16 1/16
96	(2) 48"*	109 1/2	14 1/2	112 3/8	16 1/2	111 1/16	16 1/16
108	(2) 48" & 12"*	121 1/2	14 1/2	124 3/8	16 1/2	123 1/16	16 1/16
120	(2) 48" & 24"*	133 1/2	14 1/2	136 3/8	16 1/2	135 1/16	16 1/16

\*48" LENGTHS NOT AVAILABLE IN 7" DIA.



P.O Box • WICHITA, KANSAS 67201  
(316) 943-2351 • FAX (316)943-2717