

# Tankless Water Heater 3"/5" Concentric Direct Vent Vertical Vent Kit Installation Instructions

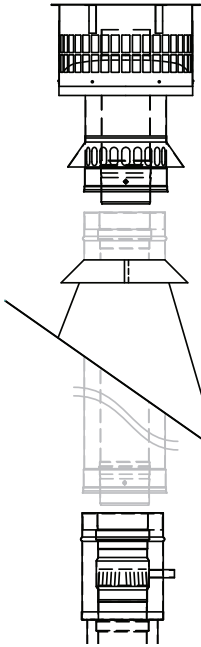

This kit contains:  
Appliance Adapter with Integrated Condensate Collector, Vertical Termination, Storm Collar, 6/12 to 12/12 Pitched Roof Flashing, Condensate Drain Line, Hardware, and Installation Instructions.

**NOTICE:** This kit does not contain any vent piping. Vent piping will need to be purchased separately to complete the installation. See the Use and Care Manual provided with the tankless water heater for maximum vent lengths.

This instruction will only cover the installation of the Metal-Fab, Inc., Sealed Combustion Vertical Vent Kit to the tankless water heater. Refer to the Owner's Use and Care Manual provided with your Direct Vent Tankless Water Heater for additional installation considerations and directions.



**WARNING :** IMPROPER INSTALLATION OF VENTING, OR FAILURE TO FOLLOW ALL INSTALLATION INSTRUCTIONS COMPLETELY, CAN RESULT IN PROPERTY DAMAGE AND/OR DEATH.



**WARNING:** SHEET METAL SCREWS ARE FOR OUTER WALL ONLY. NEVER USE SCREWS, RIVETS OR OTHER FASTENERS TO PENETRATE THE INNER PIPE WALL.



**DO NOT ATTEMPT TO CUT THIS VENTING MATERIAL, CUT SECTIONS WILL NOT SEAL AND COULD CAUSE IMPROPER OPERATION OF THE WATER HEATER.**



**NOTICE:** THIS KIT CONTAINS SHEET METAL PARTS, WHICH MAY HAVE VERY SHARP EDGES. USE LEATHER GLOVES WHEN HANDLING VENT COMPONENTS.

The Sealed Combustion Vertical Vent Kit (RTG20184) is designed for use with ONLY the following models:

RTG-66DV*	RTG-53DV*	PH-25R DVS*	ECO-180DV*
RUTG-66DV*	RUTG-53DV*	PH-20R DVS*	PTG-53DV*
RMTG-66DV*	RMTG-53DV*		

\* P - suffix for LP Gas  
\* N - suffix for Natural Gas

**It is very important that all persons who are expected to install, operate, or adjust this vent system and/or water heater read these instructions along with those instructions provided with the tankless water heater.**

Unpack the Horizontal Vent Kit, inspect all parts for damage, and make sure none of the parts are missing. Contact the supplier if there are parts missing.

**Installation Location** – After choosing the installation location for the water heater, see the Use and Care Manual provided with the tankless water heater for information and clearances, mount the water heater to the wall as instructed.

When cutting the hole, cover the vent of the water heater to prevent any debris from falling into the flue. Remove this cover prior to completing the installation

Cut a six (6) to eight (8) inch hole in the roof for the vent to pass through directly above the center of the water heater.

**Adapter/Collector Installation** – Apply a light amount of silicone lubricant to the silicone seals to help the adapter fit on the water heater. Align the adapter with the concentric vent pipe and press it down until adapter bottoms out. See Figure 1. Secure the adapter to the tankless water heater using the three machine screws provided.

**Install Adapter - Figure 1**

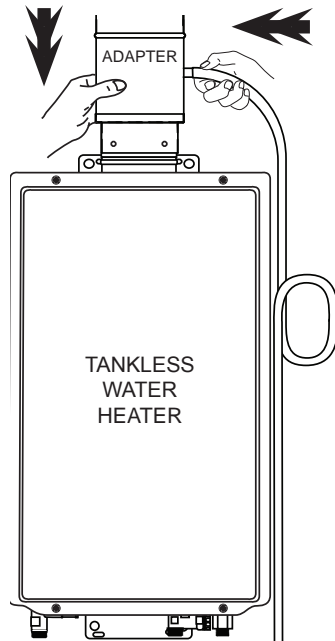

Attach the condensate drain tube to the side outlet of the collector. Use the provided clamp to secure the drain line to the collector. Form a loop in the drain tubing and secure with the two provided wire ties.

Pour a small amount of water into the end of the drain tube, so that the loop is about half full of water. This is to prevent exhaust gases from entering the inside of the building or room.

## CONCENTRIC VENT JOINT ASSEMBLY

Connections between vent and fittings are male/female type. The inner duct is sealed with an integral seal gasket and the joint is mechanically secured via the overlapping outer wall of the double wall pipe.

Joints are assembled per the following steps:

**Joint Assembly - Figure 2**

A. Before assembly, observe that the seal gasket is located within the female inner pipe joint. Locate next pipe or fitting with male inner pipe joint and insert to begin engagement of inner pipe joint. To help the joints slide together, apply a light amount of silicone or water-based lubricant to the silicone seals.

B. As the joint further engages, align the male and female ends of the outer wall of each pipe so that they begin to engage as the pipes are further pushed together.

C. Pipe joint is fully engaged when the female end of the outer pipe comes in contact (or is at least within 1/16<sup>th</sup> inch) to the base of bead on the male end of the adjoining vent pipe.

D. When possible look within the pipe assembly to verify that no sign of seal gasket is showing. Complete the joint assembly by securing the joint using #8 x 1/2" sheet metal screws (3 per joint) at each pre-punched hole on the female end of each joint.

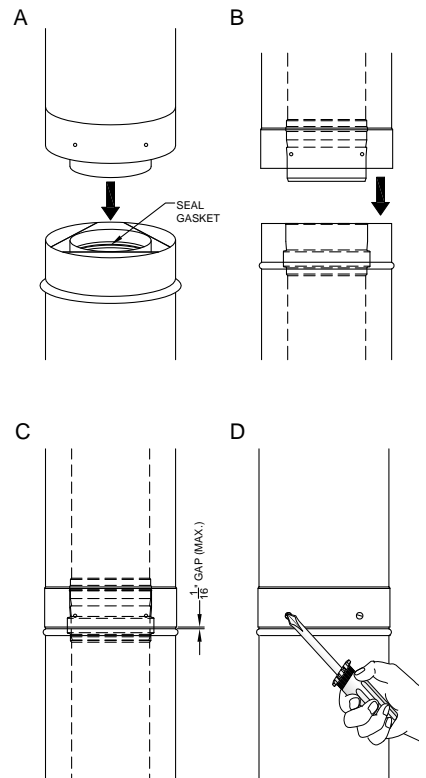

**Vertical Pipe** – Attach a length of pipe to the top of the adapter with integrated condensate collector, completely seat and secure the connection per the joint assembly instructions.

The vent pipe will need to stick through the roof by at least two (2) feet, so that the flashing can be properly installed. See the Use and Care Manual provided with the tankless water heater for maximum vent lengths. See Figure 3.

**Roof Flashing** – From outside, slide the pitched cone roof flashing over top of the vent pipe, leave six (6) to twelve (12) inches of vent pipe above the flashing, no more than three (3) feet. Secure and seal the flashing with appropriate fasteners and methods for the roofing material used.

**Storm Collar** – Slide the storm collar around the pipe above the flashing, slip the tab of the collar into the buckle and bend the tab over, pulling the collar as tight around the pipe as possible. See Figure 4.

Apply a bead of silicone sealant completely around the top of the storm collar where it meets the vent pipe.

**Vertical Termination**

– Align and press the vertical termination assembly down onto the vent pipe. Completely seat and secure the connection per the joint assembly instructions.

**Clearance Considerations** - The concentric vent piping and fittings are certified for a clearance of zero (0) inches to combustible surfaces.

**Vertical Pipe - Figure 3**

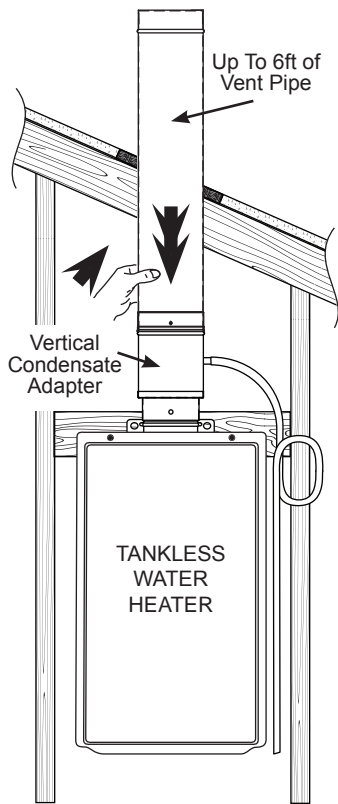

**Termination and Flashing - Figure 4**

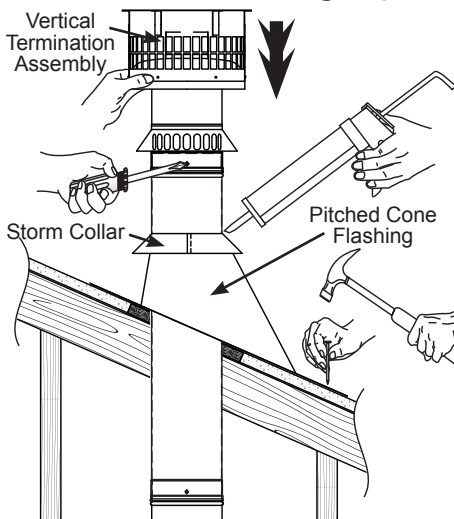

**Completed Vent Kit Installation**

Installation is complete. Refer to Owner's Use and Care Manual provided with your Direct Vent Tankless Water Heater for initial operation checks to ensure proper operating conditions.

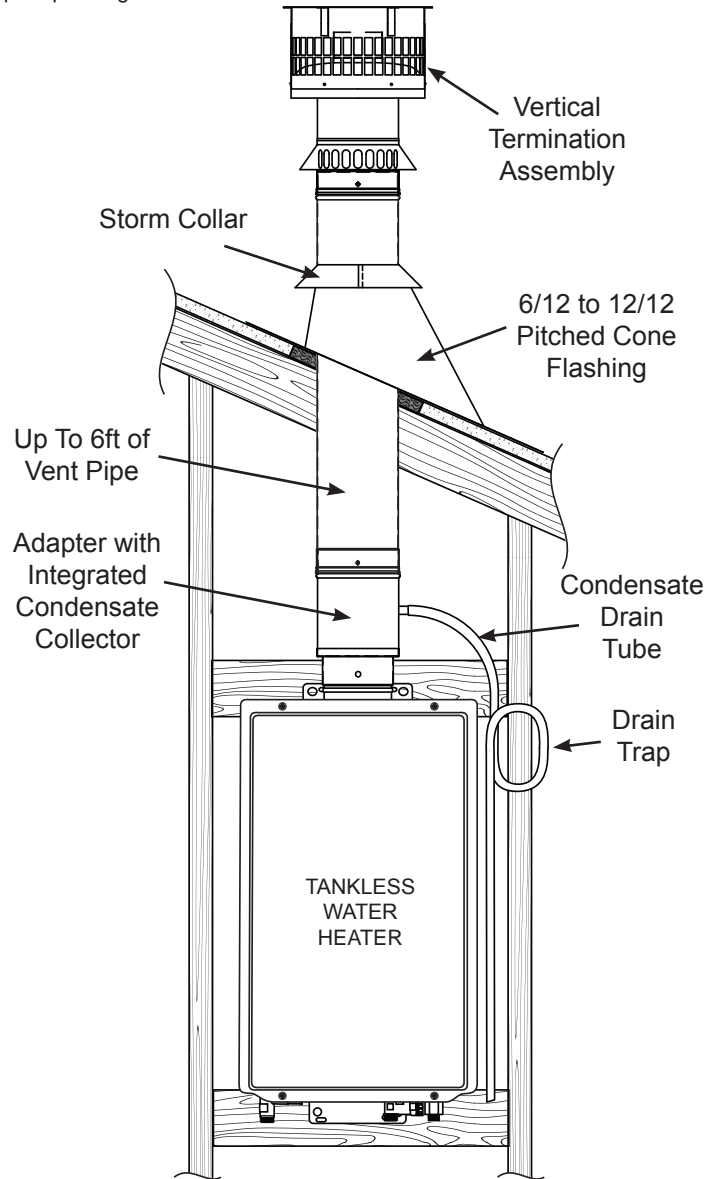

This kit can be extended up to the maximum allowable lengths as listed in the Use and Care Manual provided with the water heater. NOTICE: If a vent length of more than two (2) feet straight up from the top of the water heater is needed, a condensate collector must be installed at the water heater.

The material used in this vent kit has been approved by the water heater manufacturer.



**DO NOT ATTEMPT TO USE ANY VENTING BY ANOTHER MANUFACTURER WITH THIS VENT KIT.**

If you need service refer to these instructions and the instruction manual that came with the water heater for additional information. Should you have any questions about your new water heater or vent kit, or if these require adjustment, repair, or routine maintenance, it is suggested that you first contact your installer, plumbing contractor or previously agreed upon service agency. In the event the firm has moved, or is unavailable, refer to the telephone directory, commercial listings or local utility for qualified service assistance. Should your problem not be solved to your complete satisfaction, you should then contact the Manufacturer's National Service Department. Refer to the section titled "IF YOU NEED SERVICE" in the Use and Care Manual provided with your water heater(s) for contact information and procedures.