



# INSTALLATION INSTRUCTIONS FOR DIRECT VENT CHIMNEY LINER SYSTEM FOR USE WITH GAS APPLIANCES

## APPLICATION

These instructions apply to Metal-Fab Direct Vent Chimney Liner System. Metal-Fab Direct Vent terminations, in combination with the gas appliance, has been tested and listed as a decorative gas appliance system or as a direct vent heater system by a major testing agency such as UL, AGA, CGA, Omni or Warnock Hersey.

## IMPORTANT

Read instructions carefully before starting the installation. Failure to follow these instructions may create a fire or other safety hazard, and will void the warranty. Be sure to check the appliance manufacturer's installation instructions for specific venting and clearance to combustible requirements, which may vary from one appliance to another. Do not extend the venting system in excess of the distance prescribed in the appliance manufacturer's installation instructions.

## INSTALLATION PRECAUTIONS

The Metal-Fab Direct Vent System is an engineered product that has been designed and tested for use with an approved list of direct vent gas appliances. The Metal-Fab warranty will be voided and serious fire, health, or other safety hazards may result from any of the following actions:

- Installation of any damaged Chimney Liner component.
- Unauthorized modification of the Chimney Liner System.
- Installation of any component part not manufactured or approved by Metal-Fab Inc.
- Installation other than as instructed by Metal-Fab and the appliance manufacturer.

Consult your local building codes before beginning the installation.

## WARNING

**Always maintain required clearances (air spaces) to nearby combustibles to prevent a fire hazard.** Be sure to check manufacturer's installation instructions for minimum clearance requirements between the outer walls of the vent pipe/liner system and nearby combustible surfaces. Be sure to check the vent termination clearance requirements from decks, windows, soffits, gas regulators, and air supply inlets, as specified in local building codes.

**The gas appliance and vent system must be vented directly to the outside of the building, and never be attached to a chimney serving a separate solid fuel or gas-burning appliance.** Each direct vent gas appliance must use its own separate vent system. Common vent systems are prohibited.

## SAFETY PRECAUTIONS FOR THE INSTALLER

- Wear gloves and safety glasses for protection.
- Exercise extreme caution when using ladders or on roof tops.
- Be aware of electrical wiring locations in walls and ceilings.

## PARTS LIST

The Metal-Fab Direct Vent Chimney Liner System offers a complete line of component parts for installation. Please see our catalog for details.

Number	Description
4DV3A	Co-Linear Flex Connectors
4DVLTK	Direct Vent Chimney Liner Termination Kit (Baseplate & Co-Linear to Co-Axial Adaptor)
4DVLA	Co-Axial to Co-Linear Appliance Connector (Standard)
4DVTA	Co-Axial to Co-Linear Appliance Connector (Connector for Travis Industries)
4DVT	Vertical Termination Cap, High Wind
FLX0325	3" Chimney Liner Flex (25' Long)
FLX0335	3" Chimney Liner Flex (35' Long)
3FPC	3" Flex Puller/Connector

## PLANNING INSTALLATION

The Direct Vent Liner System was designed to be installed in an existing masonry chimney or zero clearance chimney, and connect to stove, insert or other appropriate direct vent gas appliance (See FIG. 1). It is important to carefully measure the length of flex needed to reach from the appliance outlet to the termination cap. If the flex length is too short, a flex coupler will be needed to attach an additional length of Flex Liner to make up the difference. If the flex length is too long, the liner could sag below the appliance outlet which could result in a potential fire hazard.

Note: For installation in a zero clearance chimney, you must have at least 7" inner diameter to run the two lines of Flex Liner needed.

## INSTALLATION IN MASONRY OR ZERO CLEARANCE CHIMNEY

**Step 1.** Measure and record dimensions to determine total Flex Liner length requirements (See instructions below for details).

**Step 2.** Insert a rope through the end of the Flex Connector and tie a knot at the end of the rope. Attach the Flex Connector to the Flex Liner using four sheet metal screws as shown (See FIG. 2). Carefully feed the liner down the chimney (masonry or zero clearance) and out through the damper. One person should feed the liner through the chimney bottom.

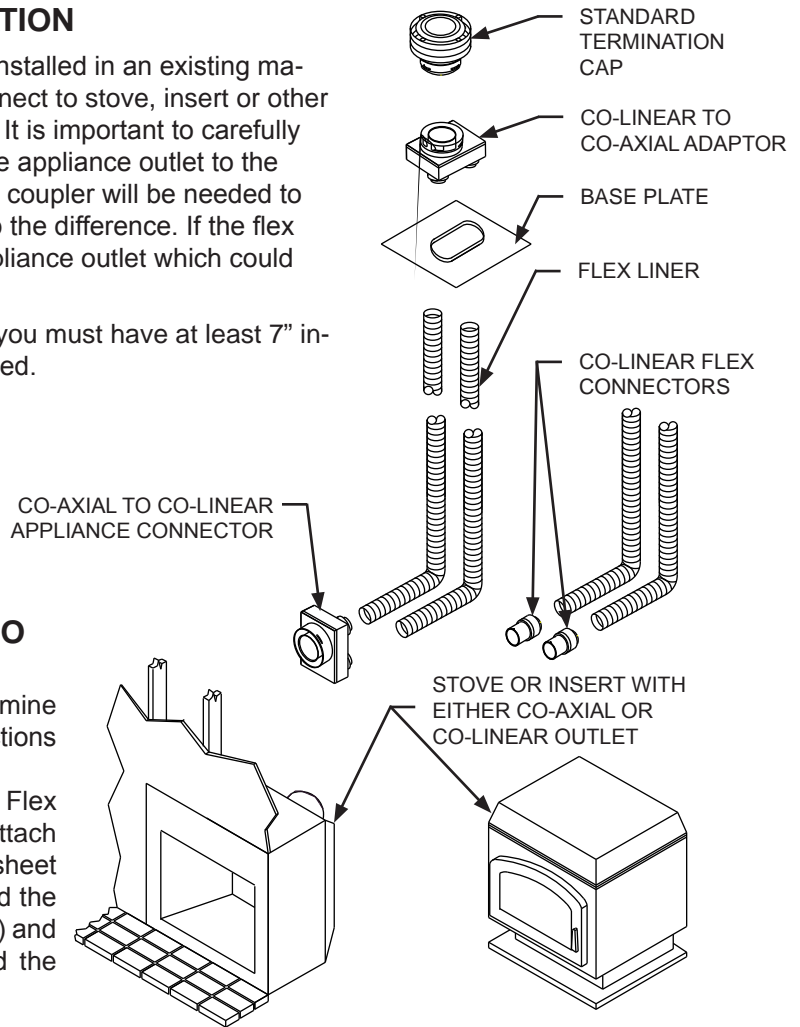

FIG. 1

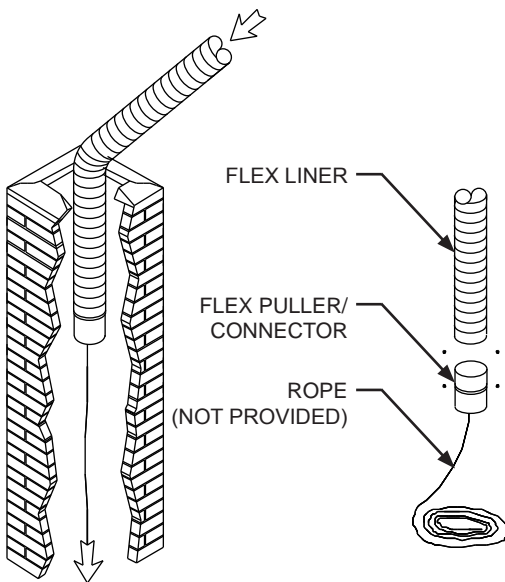

FIG. 2

Note: If additional lengths of Flex Liner are needed to span the Chimney height, use a Flex Coupler to connect the pieces of Flex Liner together. Connect the flex to the coupler by using four sheet metal screws for each side (See FIG. 3).

**Step 3.** After carefully feeding the flex liner down the chimney to the bottom, form an angle to line up the Flex Liner with the vent opening on the appliance.

**IMPORTANT:** Do not let the Flex Liner sag below the level at which it will connect to the appliance or connector. This could allow hot gas to become trapped and potentially become a fire hazard. The Flex Liner path should always be sloped up toward the Termination Cap.

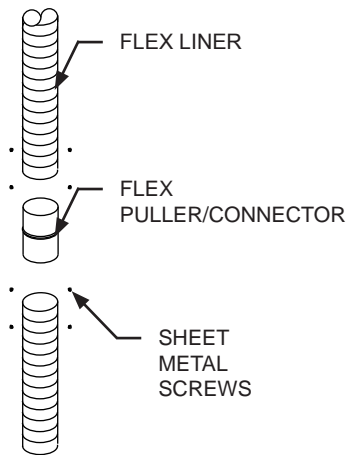
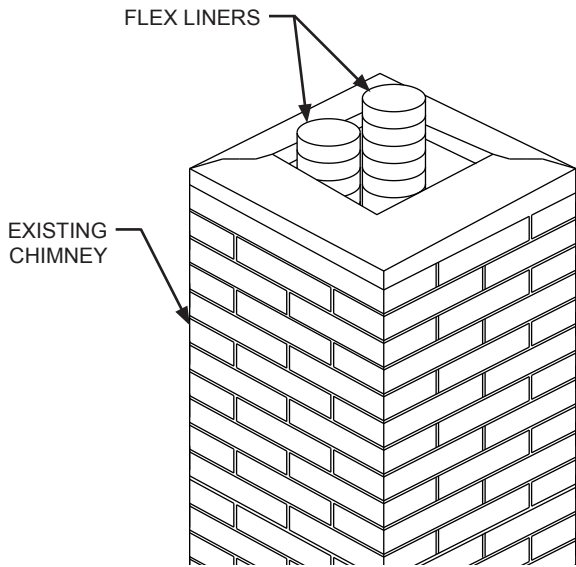

FIG. 3

**Step 4.** Remove the Flex Puller from the Flex Liner and temporarily secure the Flex Liner at the top of the chimney. Be sure to leave 2-3 inches of flex above the existing chimney to allow for connection to the Termination Kit (Baseplate and Adaptor) (See FIG. 4).



**FIG. 4**

**Step 5.** Repeat Steps 1-4 for the second length of Flex Liner.

**Step 6.** At the top of the chimney, slide the Baseplate over the two ends of the Flex Liner and secure it to the surrounding masonry using masonry anchor bolts. Before installing the baseplate, run a bead of non-hardening sealant between the Baseplate and the masonry to prevent moisture from entering the chimney (See FIG. 5).

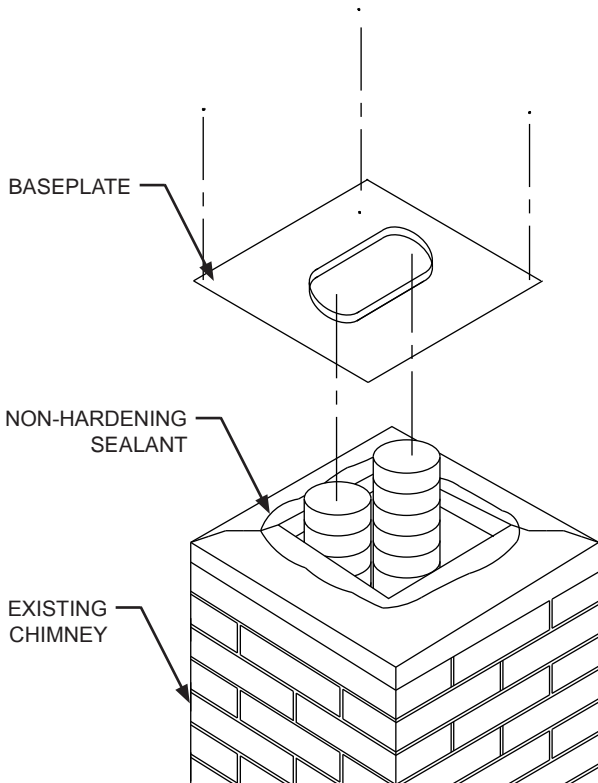

**FIG. 5**

**NOTE:** Verify that there is sufficient room to mount the baseplate on to the masonry. You must have a level surface in order to install the baseplate properly.

**Step 7.** Attach the Flex Liner ends at the top of the chimney to the Co-Linear to Co-Axial Adaptor. Use four sheet metal screws to connect each Flex Liner run to Adaptor. Mount the Adaptor to the Baseplate using sheet metal screws as shown (See FIG. 6).

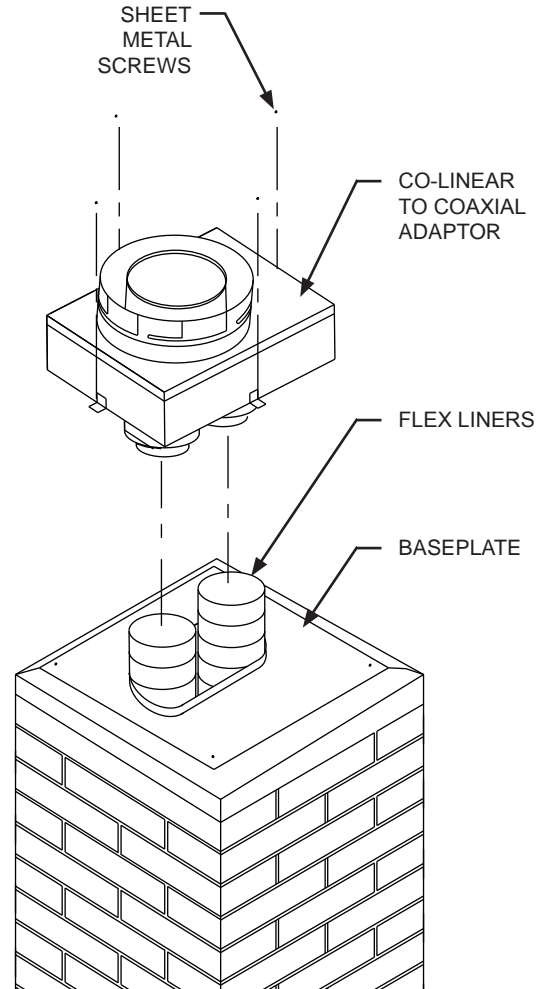

**FIG. 6**

**Step 8.** Twist lock the Vertical Termination Cap to the Adaptor (See FIG. 7).

NOTE: If you are planning to extend the height of the chimney using Direct Vent Pipe, please refer to Sure Seal Direct Vent Installation Instructions (L2442) for information concerning the proper procedure and restrictions of Sure Seal Direct Vent Pipe. Also, consult the appliance manufacturer for any height restrictions on the chimney.

**Step 9.** Depending upon the type of connection that your appliance has, it will require either the Co-Linear Flex Connectors or a Co-Axial to Co-linear Connector (See FIG. 8).

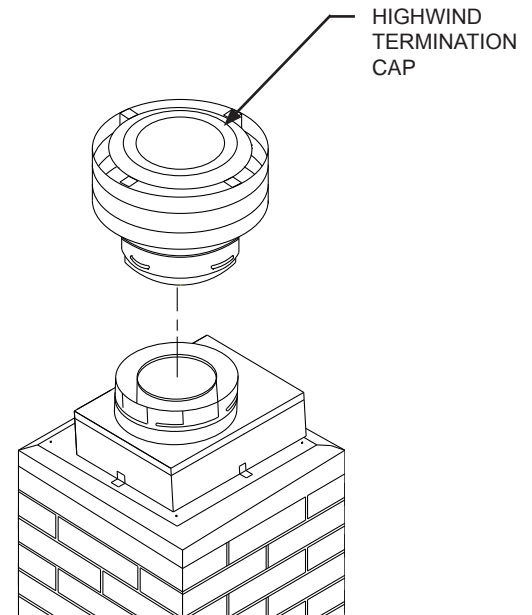

FIG. 7

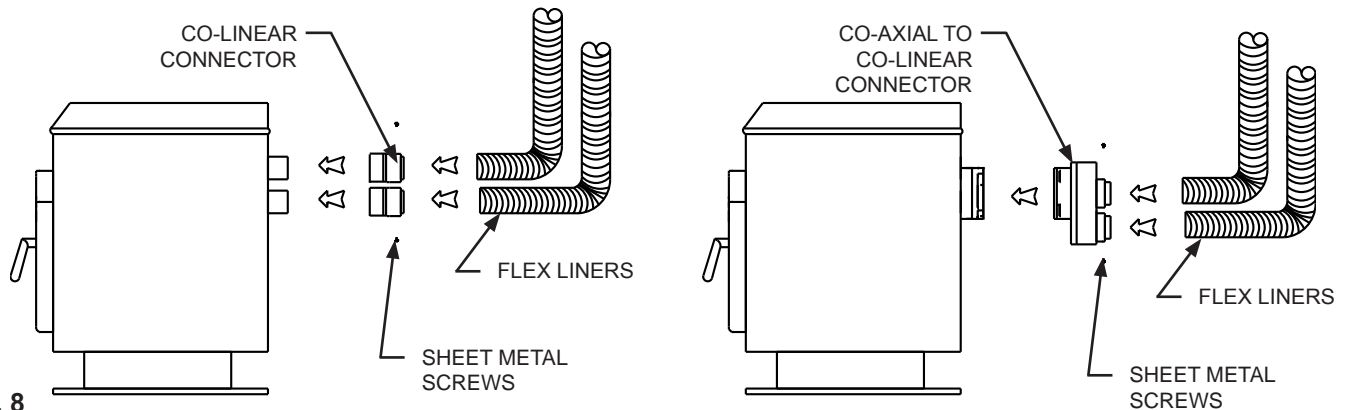

FIG. 8

## GENERAL MAINTENANCE

Conduct an inspection of the venting system semiannually. Recommended areas to inspect are as follows:

1. Check areas of the Venting System which are exposed to the elements for corrosion. These will appear as rust spots or streaks, and in extreme cases holes. These components should be replaced.
2. Remove the cap and remove any bird nests, or other foreign material.
3. Check for evidence of excessive condensate, such as water droplets forming in the liners, and subsequently dripping out at joints. Continuous condensate can cause corrosion of caps, liners and fittings. It may be caused by having exterior portions of the system being exposed to cold weather.



800-835-2830  
P.O. BOX 1138 • WICHITA, KANSAS 67201  
(316)943-2351 • FAX (316) 943-2717  
info@metal-fabinc.com • www.metal-fabinc.com