



# MODEL: MFD3 CURTAIN-TYPE FIRE DAMPERS 3-HOUR RATING



UL CLASSIFIED  
(SEE COMPLETE  
MARKING ON PRODUCT)



### 3 HOUR RATING

For use in fire barriers rated for 4 hours or less.

#### Standard Construction:

- Frame:** Roll Formed 22 Ga. Galvanized Steel with Safety Edge. Width and height dimensions available in 1/4" increments.
- Blades:** Roll Formed 24 Ga. Galvanized Steel, Curtain Type.
- Springs:** Stainless Steel.
- Transition:** 20 Ga. Galvanized Steel.
- Finish:** Mill Galvanized Standard.

#### Options:

- Type-A, Type-B or Type-C
- Fusible link 165°F, 212°F, 286°F
- Vertical or Horizontal applications
- Sleeve options are 20 Ga., 18 Ga., or 16 Ga., and 12", 14" or 16" long
- Low pressure, medium/high pressure or high pressure
- Microswitch

### TYPICAL VERTICAL DAMPER

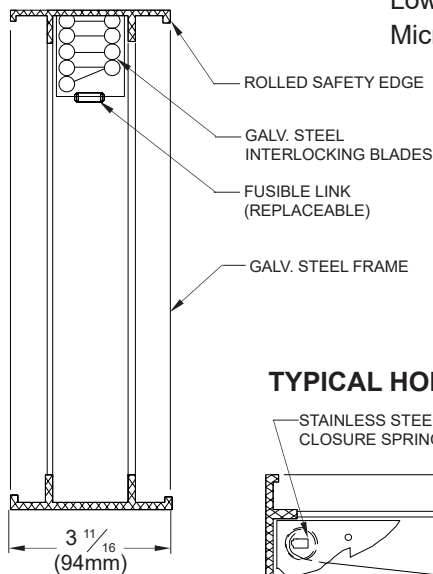

### TYPICAL HORIZONTAL DAMPER

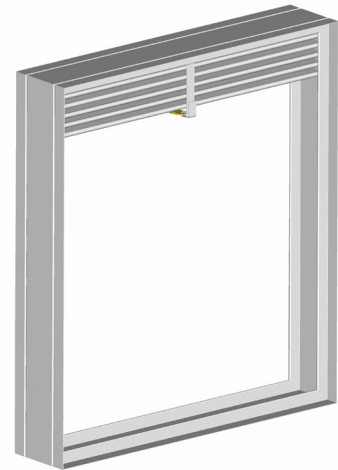
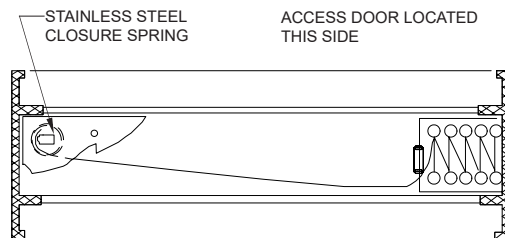

### DUCT SIZE LIMITATIONS:

	<u>MIN.</u>	<u>MAX. SINGLE SECTION</u>	<u>MAX. MULTI SECTION</u>
Vertical A	4.25"W x 3.75"H	60.25"W x 60.25"H	
Vertical B	4.25"W x 2.00"H	60.25"W x 55.25"H	
Vertical C	4.00" DIA.	59.00"W x 53.00"H	
Horizontal A	5.50"W x 4.00"H	40.25"W x 40.25"H	80.00"W x 40.00"H
Horizontal B	5.50"W x 2.25"H	40.25"W x 36.25"H	80.00"W x 36.00"H
Horizontal C	5.25" DIA.	39.00"W x 34.00"H	

Project:  
Location:  
Architect:  
Engineer:

Contractor:  
Address:  
P.O. Number:  
Date:

## MODEL STYLES

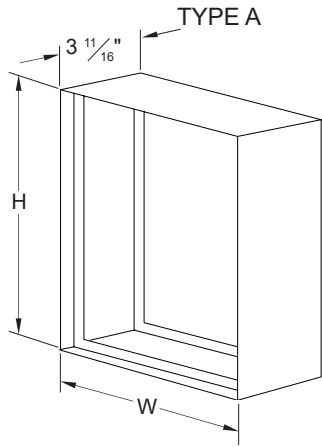

TYPE A  
SQUARE TRANSITION

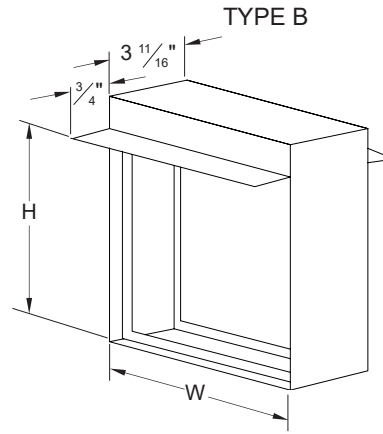

TYPE B  
ROUND TRANSITION

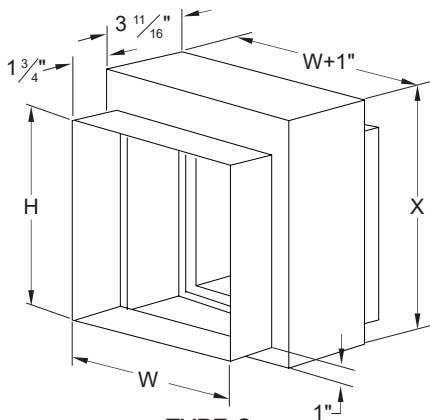

TYPE C  
SQUARE TRANSITION

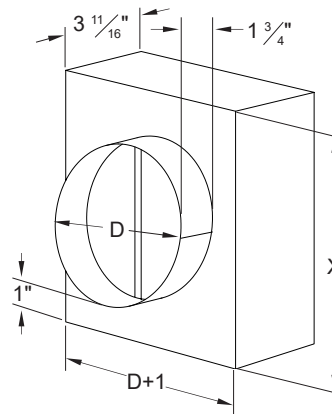

SUGGESTED INSTALLATION

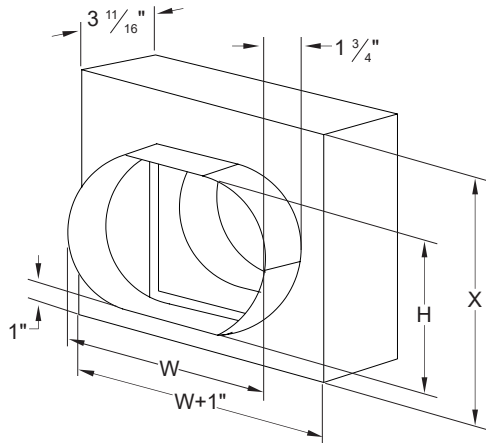
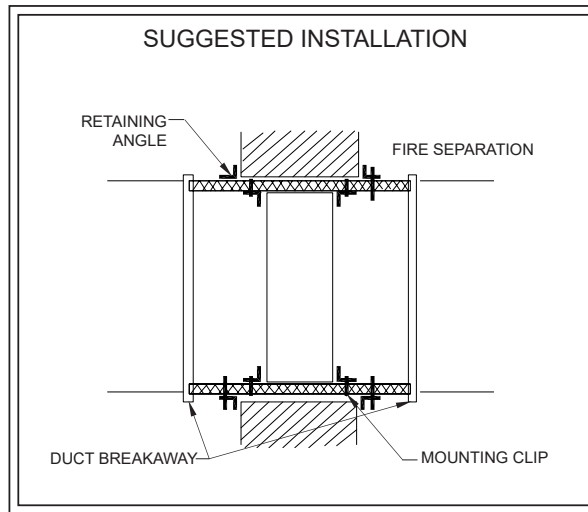

TYPE C  
OVAL TRANSITION

W = WIDTH (DUCT)

H = HEIGHT (DUCT)

D = DIAMETER

X = VARIABLE (SEE SIZE CHART)

**NOTE:** Independent tests have shown a need for fire dampers in some HVAC systems to close against air flow. UL tests at present evaluate the performance and reliability of fire dampers under static and dynamic conditions. We recommend Metal-Fab, Inc. U.L. Classified dynamic closure fire dampers in HVAC systems that involve the possibility of fire dampers having to close against air flow.

