



CORR/GUARD INSTALLATION INSTRUCTIONS

This symbol on the nameplate
means this product is listed by
Underwriters Laboratories Inc.
Tested to UL1738 / CAN / ULCS636-1995
Listing No. MH26687
Testing No. 11EN



CORR/GUARD

PRESSURE RATED VENTING SYSTEM AL29-4C[®] STAINLESS STEEL

CONDENSING APPLIANCES
CAT. II, III, IV APPLIANCES
FUME EXHAUST
3"(76mm)-24"(610mm) DIAMETERS

**IMPORTANT: DONOTINSTALLWITHOUTFIRSTREADINGTHESEINSTRUCTIONS
VERY CAREFULLY.**

EXAMINE ALL COMPONENTS FOR POSSIBLE SHIPPING DAMAGE BEFORE INSTALLATION. PROPER JOINT ASSEMBLY IS ESSENTIAL FOR A SAFE INSTALLATION. FOLLOW THESE INSTRUCTIONS EXACTLY AS WRITTEN. CHECK SEVERENESS OF JOINTS UPON COMPLETION OF ASSEMBLY. THIS VENTING SYSTEM MUST BE FREE TO EXPAND AND CONTRACT. SUPPORT SYSTEM IN ACCORDANCE WITH THESE INSTRUCTIONS. CHECK FOR UNRESTRICTED MOVEMENT THROUGH WALLS CEILINGS, AND ROOF PENETRATIONS. DIFFERENT MANUFACTURERS HAVE DIFFERENT JOINT SYSTEMS AND ADHESIVES. DO NOT MIX PIPE, FITTINGS, OR JOINING METHODS FROM DIFFERENT MANUFACTURERS.

CORR/GUARD VENTING SYSTEM INSTALLATION INSTRUCTIONS

Corr/Guard is manufactured as a Single Wall vent designated as CGSW; and Double Wall vent designated as CG. Corr/Guard is a special stainless steel venting system for gas-fired appliances listed as Cat. II, III & IV or in Canada, Type BH Gas Venting Systems per ULC-636, with rated operating temperature of 550° F (287° C), Corr/Guard is rated for positive pressure of 10" (254mm) w.c. for 3" (76mm) diameter through 5" (127) diameter and 6" (152mm) w.c. for 6" (152mm) diameter through 24" (610mm) diameter. **Refer to TABLE 1 for Operating Temperatures and Clearance to Combustibles.** Metal-Fab, Inc. recommends the system be inspected once a year by a qualified service technician.

Venting system design may be limited by appliance performance. Consult appliance installation instructions to determine proper sizing and limitations such as maximum horizontal length and height, maximum number of elbows or offsets, connecting two or more appliances to a common venting system, and other limitations that may affect design and installation. **It is the responsibility of the installer to contact local building and fire officials concerning any installation restrictions and/or inspection requirements that may apply.** Permits may be required before starting an installation. Installation is to be in accordance with local building code requirements and National Codes: USA – NFPA 54 ANSI-Z223.1 or NFPA 211. In Canada – CAN/CGA-B149.1 or CAN/CGA-B149.2 Propane Installation Code as applicable.

TABLE 1

Rated Operating Temperatures		Minimum Clearance Enclosed		Minimum Clearance Unenclosed	
Pipe Dia.	Temp.	Horiz.	Vert.	Horiz.	Vert.
3"-5" (76mm - 127mm) (CG) Double Wall	300°F (149°C)	3" (76mm)	1" (25mm)	1" (25mm)	1" (25mm)
	480°F (249°C)	6" (152mm)	1" (25mm)	1" (25mm)	1" (25mm)
	550°F (288°C)	N/A	N/A	1" (25mm)	1" (25mm)
3"&4" (76mm - 102mm) (CGSW) Single Wall	400°F (204°C)	8" (203mm)	4" (102mm)	1" (25mm)	1" (25mm)
	480°F (249°C)	8" (203mm)	4" (102mm)	2" (51mm)	2" (51mm)
	550°F (288°C)	N/A	N/A	2" (51mm)	2" (51mm)
5" (127mm) (CGSW) Single Wall	400°F (204°C)	N/A	6" (152mm)	1" (25mm)	1" (25mm)
	480°F (249°C)	N/A	6" (152mm)	2" (51mm)	2" (51mm)
	550°F (288°C)	N/A	N/A	2" (51mm)	2" (51mm)
6"-12" (152mm - 305mm) (CG) Double Wall	480°F (249°C)	N/A	1" (25mm)	1" (25mm)	1" (25mm)
	550°F (288°C)	N/A	N/A	1" (25mm)	1" (25mm)
14"-24" (356mm - 610mm) (CG) Double Wall	480°F (249°C)	N/A	1" (25mm)	5" (127mm)	1" (25mm)
	550°F (288°C)	N/A	N/A	5" (127mm)	5" (127mm)
6"-12" (152mm - 305mm) (CGSW) Single Wall	480°F (249°C)	N/A	N/A	2" (51mm)	2" (51mm)
	550°F (288°C)	N/A	N/A	2" (51mm)	2" (51mm)
14"-24" (356mm - 610mm) (CGSW) Single Wall	480°F (249°C)	N/A	N/A	6" (153mm)	6" (153mm)
	550°F (288°C)	N/A	N/A	6" (153mm)	6" (153mm)

GENERAL

Corr/Guard is to be installed in accordance with these installation instructions and those of the appliance manufacturer. For conditions and applicable restrictions not specifically mentioned herein, contact building or fire officials having jurisdiction in your area. The following is a guide to assist a professional installer:

- Proper operation of the venting system and appliance is dependant on the use of all parts specified by Metal-Fab for use in the particular installation. System performance may be affected if the proper assembly of all required parts is not accomplished.
- Refer to appliance's instructions to determine proper sizing and connection of the venting system to the appliance.
- Corr/Guard Model CG double wall vent may be used with Model CGSW single wall vent within the same vent system.
- Tee sections should only be used in conjunction with a drain on appliances tested for use with a drain, or if allowed by the appliance manufacturer for multiple appliance connections.
- If required by the appliance manufacturer, a drain fitting must be located as close as possible to the appliance flue outlet. Unless a drain fitting is supplied with the appliance, install only a Corr/Guard Drain Fitting.
- More than one Category II, III or IV appliance may not be connected into the same vent system, unless the appliance manufacturer specifically approved such a system and the appliances are designed for multiple venting. Cat. II, III or IV appliances MAY NOT share any part of their vent system with a natural draft appliance.
- Check the joints and seams for gas tightness when using the venting system with a Cat. III or Cat. IV appliance.
- Except for installation in one and two family dwellings, a venting system that extends though any zone above that on which the connected appliance is located shall be provided with an enclosure having a fire resistance rating equal to or greater than that of the floor or roof assemblies through which it passes.
- Corr/Guard shall not be routed into, through, or within any other vent, such as an existing masonry or factory-built chimney flue that is connected to another appliance.
- **WARNING! Do not place or install insulation in any required clearance spaces surrounding the venting system.**
- Enclosure of exterior mounted venting systems below the roofline is recommended to limit condensation and protect from mechanical damage.

JOINT ASSEMBLY

3" - 5" (76mm - 127mm) DIAMETER CGSW

Each Corr/Guard vent component contains a seal gasket on the female end of the vent joint and locking tabs. Mechanical fastening of the joint is automatic and requires no tools. Visually check the gasket for proper location within the pipe bead during assembly or flue gases could leak, resulting in carbon monoxide poisoning. Assembly of joints is shown below:

1. Insert the male end of the vent pipe into the adjoining female vent section until the bead of the male joint stops at the edge of the female joint.
2. When properly inserted to the fullest extent, the integral locking tabs will snap into place, securing the joint. **Before Proceeding, verify that all locking tabs are engaged for each joint assembly.**

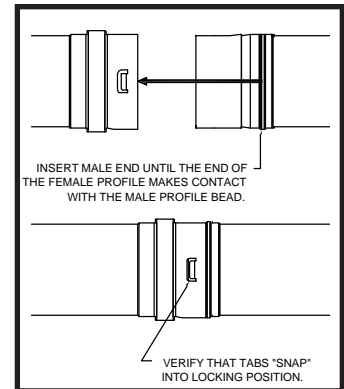

FIG. 1

JOINT ASSEMBLY

3"- 5" (76mm - 127mm) DIAMETER CG

Connections between vent and fittings are male/female type. The inner duct is sealed with an integral seal gasket and the joint is mechanically secured via the overlapping outer wall of the double wall pipe.

Joints are assembled per the following steps:

1. Before assembly, observe that the seal gasket is located within the female inner pipe joint. Locate next pipe or fitting with male inner pipe joint and insert to begin engagement of inner pipe joint.
2. As the joint further engages, align the male and female ends of the outer wall of each pipe so that they begin to engage as the pipes are further pushed together.
3. Pipe joint is fully engaged when the female end of the outer pipe comes in contact (or is at least within 3/16" 5mm) to the base of the bead on the male end of the adjoining vent pipe.

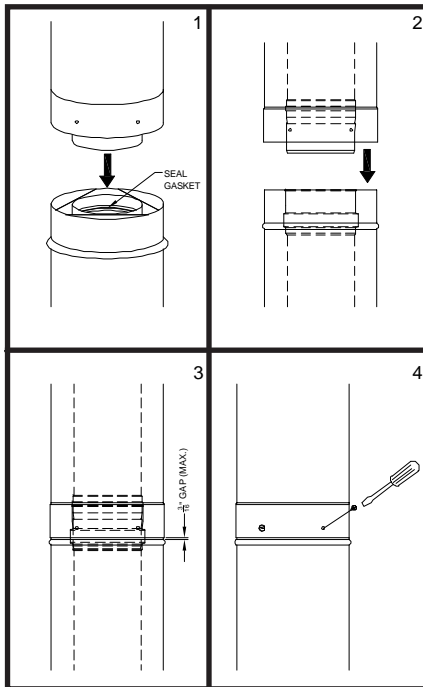

FIG. 2

4. When possible look within the pipe assembly to verify that no sign of seal gasket is showing. Complete the joint assembly by securing the joint using #8 x 1/2" sheet metal screws (3 per joint) at each pre-punched hole on the female end of each joint.

WARNING: Sheet metal screws are for Double Wall CORR/GUARD outer wall only. Never use screws, rivets or other fasteners to penetrate the inner pipe wall.

6"- 24" (152mm - 610mm) DIAMETER CGSW & CG

Connections between vent and fittings are male / female type, sealed with silicone sealant and secured with a profiled closure band.

Connection Tips (See FIG. 3):

1. Clean male and female joint ends to remove oil and contaminants with alcohol pads provided. Apply a 1/4 inch (6.4mm) bead of sealant to the male connection approximately 1/4 inch (6.4mm) below the edge. Also apply 1/4 inch (6.4mm) bead of sealant (approx. 2 inches long) along the male joint at the overlap of the welded seam.
2. Insert male end into female, twisting slightly, to ensure even distribution of sealant. Be sure sections are seated. Inspect the joint to ensure that vent gases will not escape. If necessary, apply additional sealant to any visible voids around the joint and smooth it into crevices.
3. Align profiled closure band snugly around the joint section. Insert tongue into gear clamp and tighten with 3/8-inch hex drive socket.

IMPORTANT: Profiled Vent connection band is formed to fit exactly over the joint section. This part is not symmetrical and should be installed in the proper orientation for maximum seal and support. Allow sealant to cure for a minimum 24 hours before operating the appliance. Any adhesives used in the assembly of the system are to be used within their marked time limitations.

4. For CG (double wall) joint installations, first complete steps 1 thru 3 as shown above.
5. Once the inner vent joint has been connected, locate the casing band around the casing, positioning the band between the formed beads on either casing.
6. Tighten the band snugly around the vent casings using 3/8-inch hex drive socket.

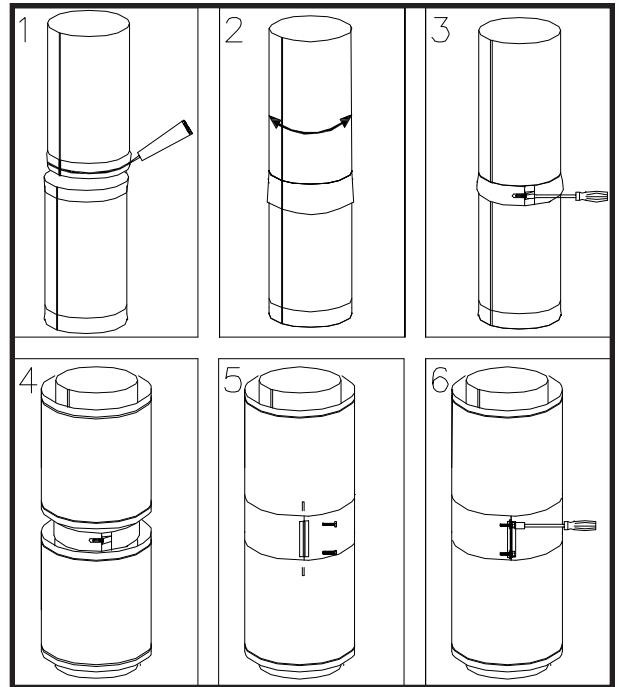

FIG. 3

INSTALLATION

HORIZONTAL VENTING

A venting system that exits through a side wall shall:

- Terminate not less than 12 inches (305 mm) above the ground.
- Be located above the snow line in geographical areas where snow accumulates.
- Not be located in traffic areas such as walkways unless the venting system is at least 7 feet (2.1 m) above the ground.

When an appliance incorporates a combustion air inlet system, the venting system shall terminate:

- 6 feet (1.8m) or more from the combustion air intake of any appliance.
- More than 3 feet (0.9m) from any other building opening, gas utility meter, service regulator or the like.
- Less distance is permitted if specified in the appliance's installation instructions.

For horizontal venting (Typical Installation Shown in FIG. 4):

- Means shall be provided for draining condensate. Due to ice build up and blockage, it is required that proper sloping be employed when the vent is installed horizontally.
- Any portion of a horizontally installed vent shall have a slope (upwards for Cat. II, III or IV appliances or downwards for Cat. III or IV appliances) not less than 1/4 inch (6.4 mm) every 12 inches (305 mm) to prevent collection of condensate at any location in the assembly.
- Use non-combustible hanger straps a minimum of every 7 feet (2.1 m) for 3"- 5" (76mm - 127mm) diameters (CG & CGSW) and every 6 feet (1.8 m) for 6" - 24" diameters (CG & CGSW) (See TABLE 2) to support the vent system from ceiling joints or other solid structures. **WARNING! Do not puncture vent system!**
- Vent must not sag or dip, providing areas for condensate to collect.

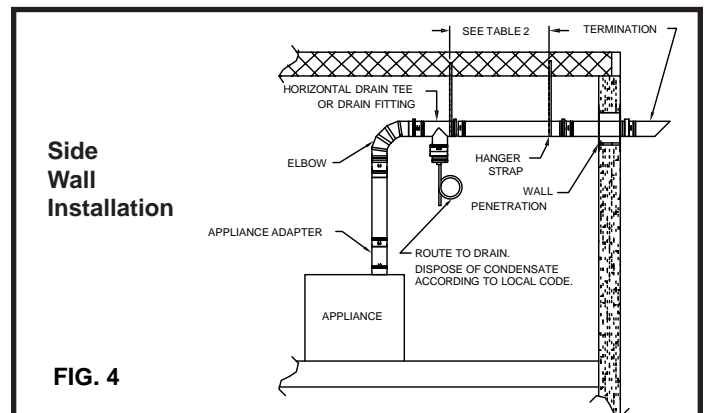

FIG. 4

TABLE 2

SUPPORT	PIPE DIA. / MODEL	DISTANCE BETWEEN SUPPORTS
HORIZONTAL RUNS	3"-5" (76mm-125mm) CG & CGSW	7' (2.13 m)
	6"-24" (152mm-610mm) CG&CGSW	6' (1.83 m)
HORIZONTAL BETWEEN ELBOWS	3"-5" (76mm-125mm) CG & CGSW	7' (2.13 m)
	6"-24" (152mm-610mm) CG&CGSW	6' (1.83 m)

WALL PENETRATION

1. Prior to installation, determine proper location of wall thimble so that a minimum slope of 1/4" (6mm) per foot is maintained in the horizontal section of vent to ensure proper flow of condensation.
2. Prepare the wall by cutting a square opening per **TABLE 3**. (Opening size adequate to insert Wall Thimble components)
3. Install the Wall Thimble by inserting the larger of the two parts on the appliance (interior) side.
4. Next, apply a bead of sealant around the edges of the exterior (smaller of the two parts) Wall Thimble component. Then install this part of the Wall Thimble by inserting the smaller collar into the other component from the previous step.

NOTE: The two horizontal cylinders of the Thimble must engage a minimum of two inches.

5. Fasten both sides of the Wall Thimble using screws or nails.
6. Once the Thimble is installed, Corr/Guard vent pipe can be inserted into the Thimble by inserting the male end first. (See **FIG. 5, 6 & 7**).
7. Assemble Corr/Guard vent from the Wall Thimble section back to the appliance.
8. Install a horizontal termination to complete the assembly.
9. Once assembly is completed, apply a bead of high-temp sealant around the pipe and the exterior plate of the Thimble to protect against weather.

WARNING! Appliance outlet temperature shall not exceed 480°F (249°C) for venting systems that penetrate walls constructed of combustible materials.

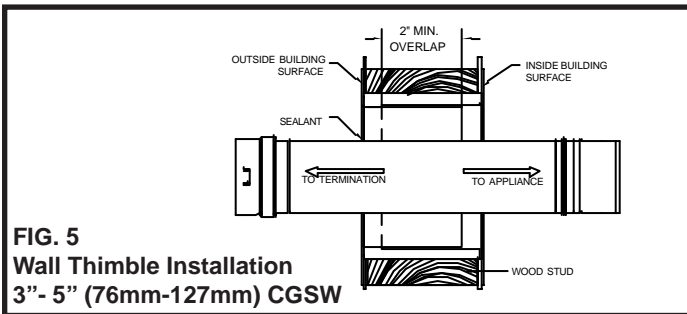

FIG. 5
Wall Thimble Installation
3"- 5" (76mm-127mm) CGSW

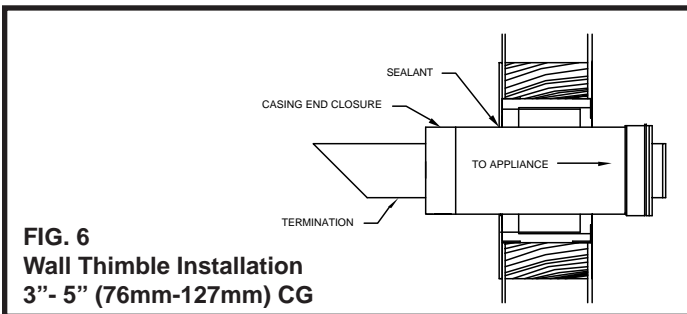

FIG. 6
Wall Thimble Installation
3"- 5" (76mm-127mm) CG

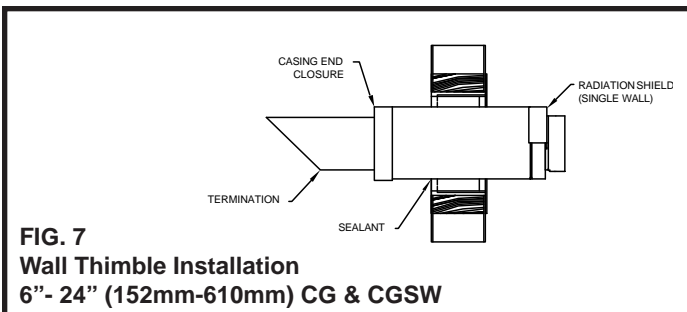

FIG. 7
Wall Thimble Installation
6"- 24" (152mm-610mm) CG & CGSW

TABLE 3

PIPE DIAMETER	FRAMING DIMENSIONS (MINIMUM)
3"-5" (76mm-127mm) CGSW (SINGLE WALL)	(PIPE DIA. +5") x (PIPE DIA. +5") (PIPE DIA.+127mm) x (PIPE DIA.+127mm)
3"-5" (76mm-127mm) CG (DOUBLE WALL)	(PIPE DIA. + 5") X (PIPE DIA. + 5") (PIPE DIA.+127mm) x (PIPE DIA.+127mm)
6"-24" (152mm-610mm) CGSW (SINGLE WALL)	(PIPE DIA. + 6") X (PIPE DIA. + 6") (PIPE DIA.+152mm) x (PIPE DIA.+152mm)
6"-24" (152mm-610mm) CG (DOUBLE WALL)	(PIPE DIA. + 6") X (PIPE DIA. + 6") (PIPE DIA.+152mm) x (PIPE DIA.+152mm)

VERTICAL VENTING

- Enclose residential exterior vent systems below the roof line or use double wall Corr/Guard (CG) to limit condensation due to cool down of flue gases.
- Unless installed in a fire rated shaft, a fire stop / vertical support is required when penetrating floors and ceilings.
- Vertical supports are to be used after each transition to vertical. Refer to **TABLE 4** for support methods and heights.
- When assembling Corr/Guard vent, always align "UP" arrow away from the appliance.
- The total equivalent length from the appliance outlet to the termination shall not exceed maximum length specified by the appliance manufacturer's installation instructions.
- Vertical terminations must terminate no less than 2' (0.61 m) above the roof or any wall or vertical structure closer than 8' (2.4 m). A vent cap or other equivalent termination is required to keep rain or debris out of the vent.

TABLE 4

SUPPORT METHODS	PIPE SIZE/MODEL	MAX.HEIGHT
PLATE SUPPORTS	3"-24" (76mm-610mm)	30' (9.1m)
	3"-12" (76mm-305mm) CGSW	30' (9.1m)
	14" - 24" (356mm-610mm) CGSW	20' (6.1m)
WALL BAND	6"-16" (152mm-406mm) CG	8' INTERIOR
	6"-12" (152mm-305mm) CGSW	8' INTERIOR
ROOF SUPPORTS (PLATE SUPPORT USED ON ROOF)	3"-24" (76mm-610mm) CG	5' (1.5m)
	3"-24" (76mm-610mm) CGSW	5' (1.5m)
WALL SUPPORTS	3"-5" (76mm-127mm) CG	6' (1.8m) EXTERIOR
	3"-5" (76mm-127mm) CGSW	6' (1.8m) EXTERIOR
	6"-24" (152mm-610mm) CG	8' (2.4m) EXTERIOR
	6"-24" (76mm-610mm) CGSW	8' (2.4m) EXTERIOR
	3"-24" (76mm-610mm) CG	30' (9.1m) INTERIOR
	3"-24" (76mm-610mm) CGSW	30' (9.1m) INTERIOR

*Wall Hanger 3"-5" CG/CGSW alignment only, not a vertical support.

1. Starting at the appliance outlet, attach the first section or appliance adaptor. (See **FIG. 8 & 9** for typical installation.)
2. Continue assembly of pipe until nearing a ceiling penetration. Locate and cut hole in floor and ceilings that will be penetrated. Hole size must maintain minimum listed clearances per **TABLE 1**.
3. Install a firestop support when penetrating the ceiling to support the vertical run of the vent system.
4. When installing a firestop in the attic, the firestop or support plate is located on top of the joist to prevent insulation from falling into the joist.
5. Continue with the vent penetrating the roof. At the roof, the opening must maintain a minimum of clearance to combustibles as specified in these instructions and on the labeled vent product.
6. Above the roof, a flashing and storm collar are required. Use high temperature sealant to seal the storm collar to the vent so that rain will not penetrate the roof opening (See **FIG. 10, 11 & 12**).

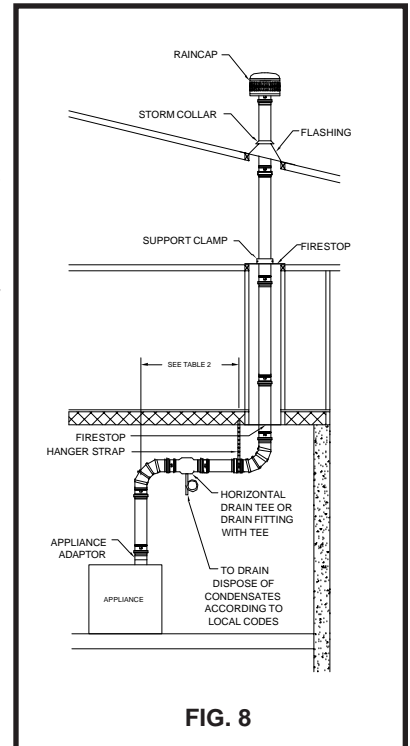

FIG. 8

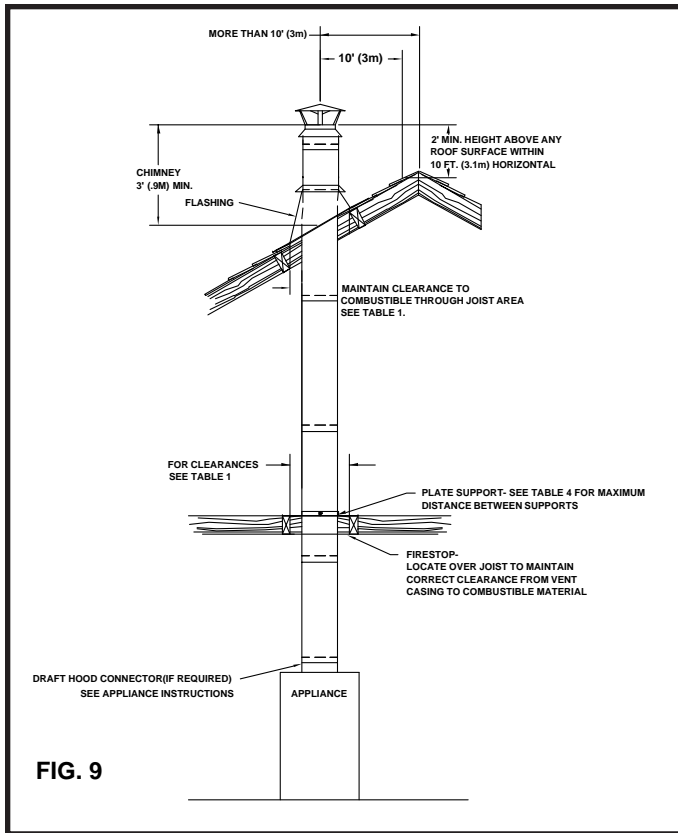

FIG. 9

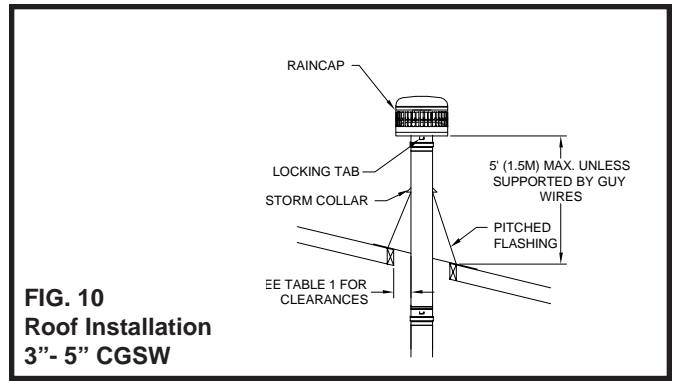

FIG. 10
Roof Installation
3"- 5" CGSW

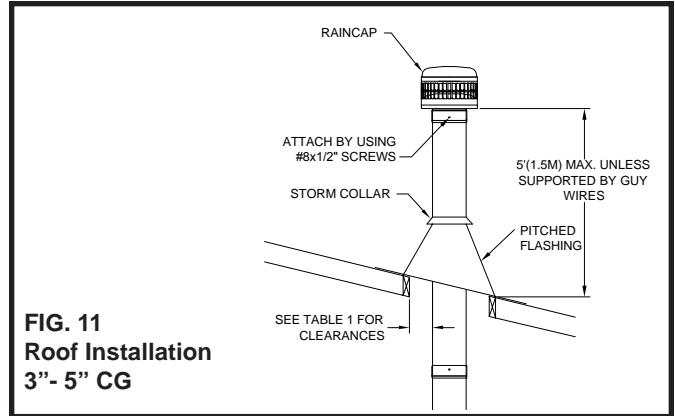

FIG. 11
Roof Installation
3"- 5" CG

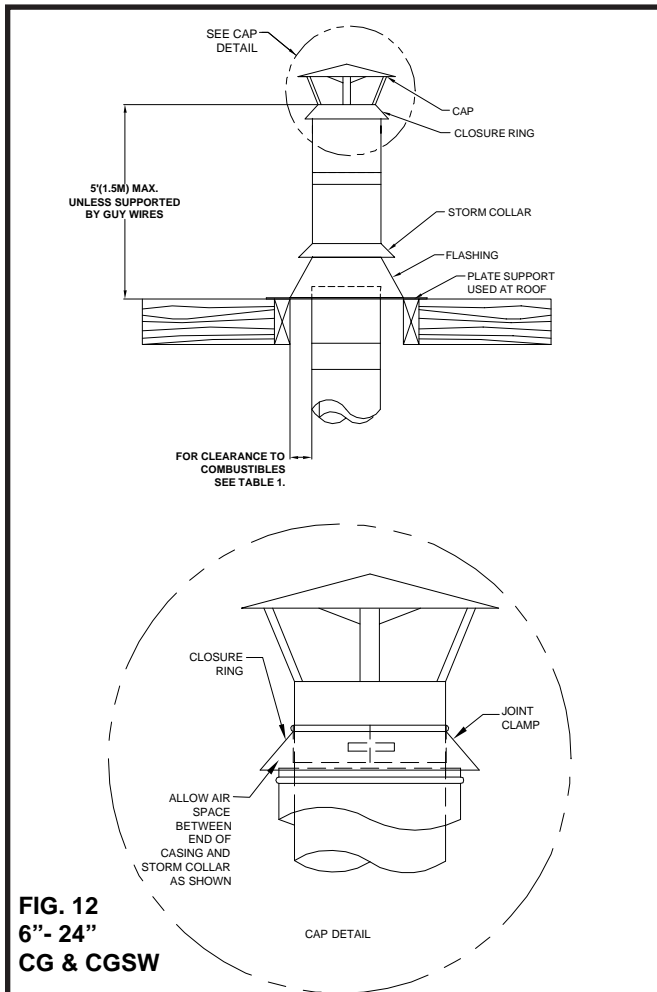

FIG. 12
6"- 24"
CG & CGSW

EXTERIOR INSTALLATION

1. There may be installations where CG & CGSW run vertically - exterior to the building and a wall band support is needed. A wall band support is used to secure the vent system to a wall while maintaining the minimum clearance to combustible construction (See FIG. 13).
2. Wall band supports must be securely fastened to a solid member of the building using appropriate fasteners for various building materials such as wood, steel siding or masonry.
3. Exterior mounted wall band supports are to be vertically spaced per TABLE 4.
4. Wall band supports are designed to be fastened to the vent by means of clamping externally to the vent. No screws are to puncture the vent wall.

WARNING: Do not rivet or screw supports to the vent or otherwise puncture the vent wall.

WARNING: Do not place any type of insulation in any required clearance spaces surrounding the vent system.

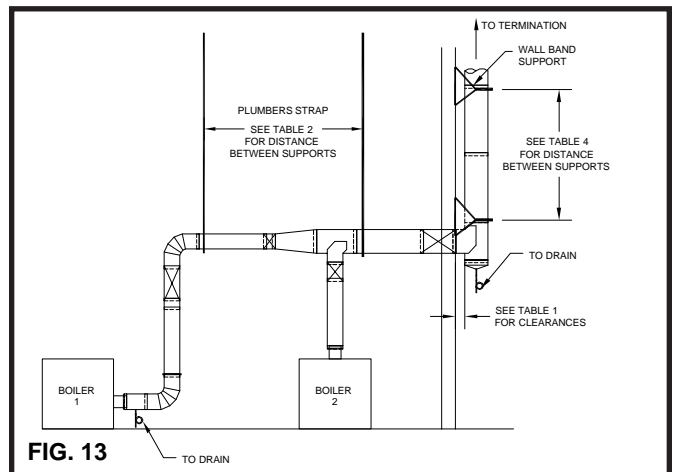

FIG. 13

VARIABLE LENGTH

For installations that require non-standard vent lengths, Corr/Guard Variable Length vent sections may be used. The vent section consists of an inner conduit that slip fits into the outer conduit, a compression band, or integral clamp and an outer casing for double wall only.

3"- 5" (76mm-127mm) CG & CGSW

To install the VL vent section, first install the inner pipe section by connecting the male section to the adjoining double or single wall vent pipe. Insert male section until the bead of the joint stops at the edge of the female end of the vent section.

Next, expand the length of the inner pipe to the necessary length and tighten the integral clamping band using a hex drive or screw driver. The VL's are adjustable from 7 1/2" to 22" (191mm to 559mm). Continue with the next section of vent, making sure to fully join the inner pipe of the vent from the female end of the VL vent.

When installing double wall, finish the VL vent assembly by installing the outer casing wall around the VL inner pipe section. Secure the casing by installing #8x1/2" sheet metal screws at prepunched holes (See FIG. 14).

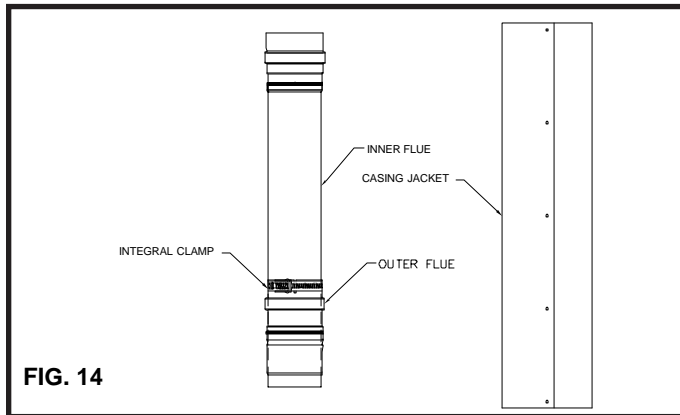

6"- 24" (152mm-610mm) CG & CGSW

To install the VL, first apply a heavy bead of P077 Sealant into the inner vent groove. Then slide the inner vent into the outer vent. Locate into position and adjust to proper length. Follow Joint Assembly Details on PAGES 2 & 3. Apply a bead of P077 Sealant at the joint of inner and outer vent and attach compression band. The 6" VL is adjustable from 7 1/2" to 10" (191mm to 254mm) and the 12" (305mm) VL is adjustable from 13 1/2" to 22" (343mm to 559mm). When installing double wall, cut outer jacket to fit between the mating vent and install using sheet metal screws (supplied) (See FIG 15).

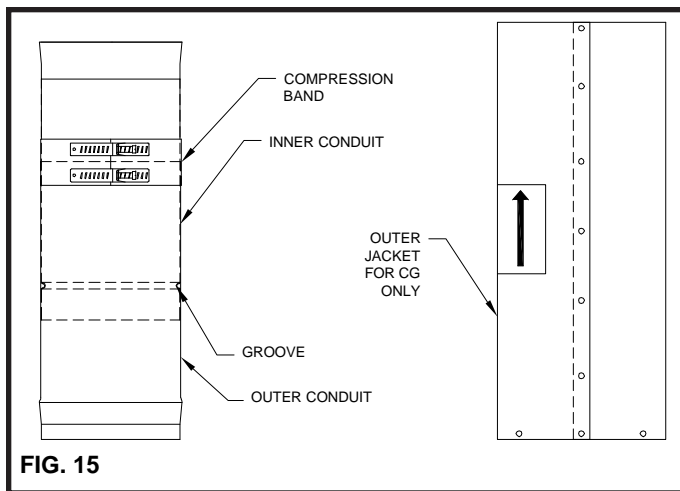

WARNING: Variable Length sections are not intended to be subjected to vertical force loads. Use appropriate support methods.

Supplementary support is required when installing offsets, elbows and non-vertical runs to prevent unacceptable stresses. Do not allow vent to sag or deflect from intended flow line during installation.

WARNING: Do not place any type of insulation in any required clearance spaces surrounding this Vent System.

CONDENSATE DRAINS

If an appliance does not supply a condensate drain and one is required per the appliance manufacturer's instructions or local codes, install a drain fitting in the horizontal conduit, as close as possible to the appliance vent collar.

WARNING: NEVER INSTALL A DRAIN IN A SYSTEM WITH AN APPLIANCE NOT INVESTIGATED FOR USE WITH A CONDENSATE DRAIN.

Corr/Guard drain fittings contain a 1/2" (13mm) diameter drain tube that should be located at the bottom of the vent or fitting when installed properly. A drain hose must be attached to the tube and a trap loop must be formed into the drain hose. The trap loop should be at least four times the appliance's rated stack pressure in inches of water column or 6 inches (153mm), whichever is less. (See FIG. 16)

When the Corr/Guard vent system is installed the system must be pressure checked to for tightness. Repair any joint leaks by disassembling and resealing following the guidelines in the Joint Assembly section of these instructions. Replace any defective component.

The Corr/Guard ventilation system, manufactured by Metal-Fab, Inc.. is constructed to exacting standards. The proper operation of this vent system is dependent on the use of correct components, proper sizing, quality of installation, and guidelines and limitations expressed by the appliance manufacturer.

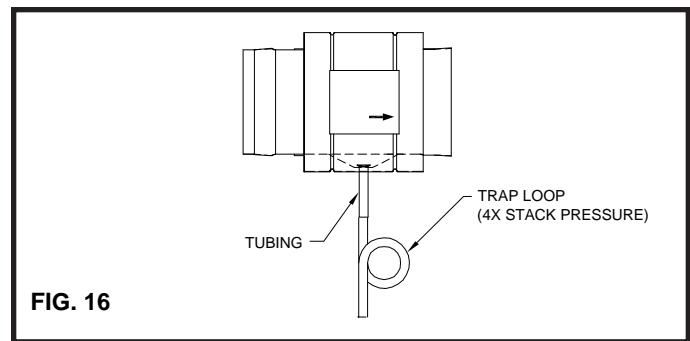

SMALL DIAMETER CGSW & CG TO CGSW & CG

Connections between vent and fittings are male / female type, sealed with silicone sealant and secured with a profiled closure band. (See FIG. 17)

Connection Tips:

1. Clean male and female joint ends to remove oil and contaminants with alcohol pads provided. Apply a 1/4 inch (6.4mm) bead of sealant to the male connection approximately 1/4 inch (6.4mm) below the edge. Also apply 1/4 inch (6.4mm) bead of sealant (approx. 2 inches long) along the male joint at the overlap of the welded seam.
2. Insert male end into female, twisting slightly, to ensure even distribution of sealant. Be sure sections are seated. Inspect the joint to ensure that vent gases will not escape. If necessary, apply additional sealant to any visible voids around the joint and smooth it into crevices.
3. Align profiled closure band snugly around the joint section. Insert tongue into gear clamp and tighten with 3/8-inch hex drive socket.

IMPORTANT: Profiled Vent connection band is formed to fit exactly over the joint section. This part is not symmetrical and should be installed in the proper orientation for maximum seal and support. Allow sealant to cure for a minimum 24 hours before operating the appliance. Any adhesives used in the assembly of the system are to be used within their marked time limitations.

4. For CG (double wall) joint installations, first complete steps 1 thru 3 as shown above.
5. Once the inner vent joint has been connected, locate the casing band around the casing, positioning the band between the formed beads on either casing.
6. Tighten the band snugly around the vent casings using 3/8-inch hex drive socket.

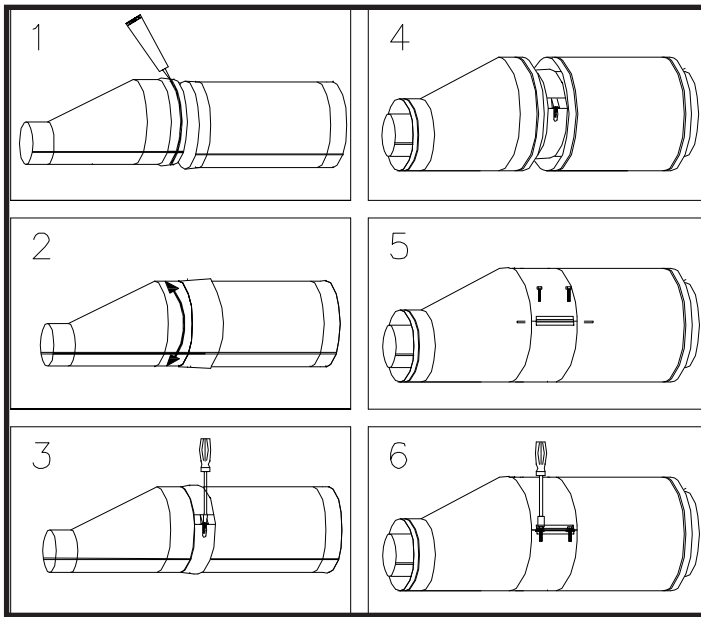

FIG. 17

MAINTENANCE INSTRUCTIONS

As with all vents, the Corr/Guard vent system should be inspected at least annually for the presence of deposits or debris and any accumulation should be removed. The vent system should also be inspected at regular periods for signs of leakage of condensate or combustion products at any joints.

If the vent system incorporates a drain hose from either an inline fitting or from a drain tee, the hose must be inspected periodically to ensure that water is in the trap loop. If a proper trap loop is not maintained, exhaust from the connected appliances may accumulate in the building area.

Where the duct is installed outside the building, the aluminized steel outer casing must be primed and painted. The painted surface should be maintained regularly to prevent possible deterioration of the casing surface. The use of stainless steel outer casing negates the need for painting.

IMPORTANT: The listing for this product is void if components other than those supplied as Listed Components by Metal-Fab, Inc. are used. All warranties, stated or implied, are void if this product and the appliances to which it is connected are not installed in accordance with their respective instructions and local code requirements.



P.O. Box 1138 • WICHITA, KANSAS 67201
(316)943-2351 • fax (316)943-2717