



INSTALLATION INSTRUCTIONS MODEL 4CG7HTL, 4CG7HTR, 4CG7HT90L & 4CG7HT90R COLLINEAR TO CONCENTRIC HORIZONTAL TERMINATIONS

Based on installation location of the water heater or boiler, determine the location of the wall penetration for the vent.

4CG7HT90L/R Installation:

1. For wall mounted water heaters that vent directly through the wall the water heater is mounted upon, the 4CG7HT90L/R termination kit is recommended.
2. Locate center of the hole vertically from the water heater vent collar. The center of this hole should be approximately 12 inches above the water heater however the termination can be connected to additional vertical venting section(s) to provide more distance from the appliance if needed.
3. Locate the center of the hole to be cut by placing the vent parts as shown in **Figure 1** onto the water heater vent collar. By assembling these parts onto the appliance, the horizontal center line of the vent can be determined.

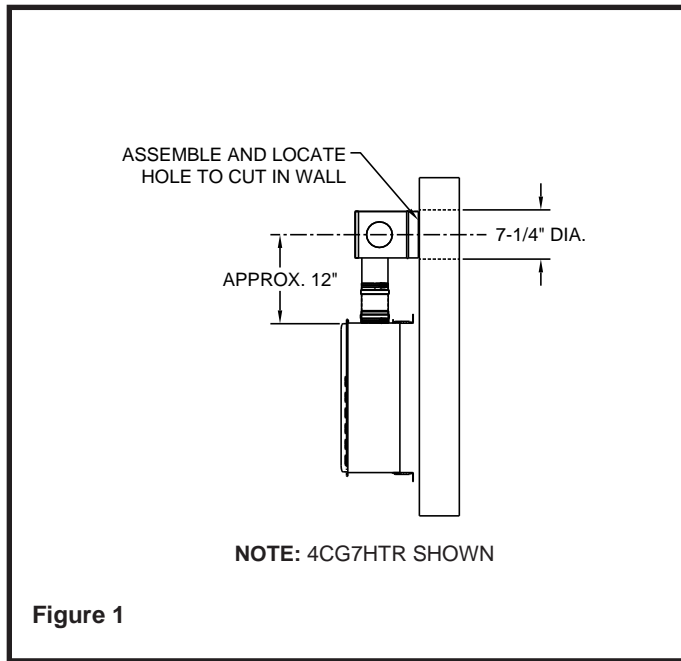

4. Using a pencil or sharp scoring tool, mark the "PILOT HOLE" location onto the wall. Using a compass or similar means, draw or score a 7-1/4 inch (minimum) diameter circle, centered by the mark previously made.
5. Remove the water heater from the wall or completely cover it using plastic and tape so dust or debris will not fall into the vent opening or any of the ventilation slots when cutting the opening through the wall.

6. Using a cutting tool suitable for the wall construction (i.e. drill, skill saw, hole saw, etc.) drill or cut the vent termination hole through the wall along the cut lines drawn in Step 4.
7. Insert the wall termination through the wall. (Note that a trim plate may be included to provide a finished look for the interior of the wall). See **Figure 2**.

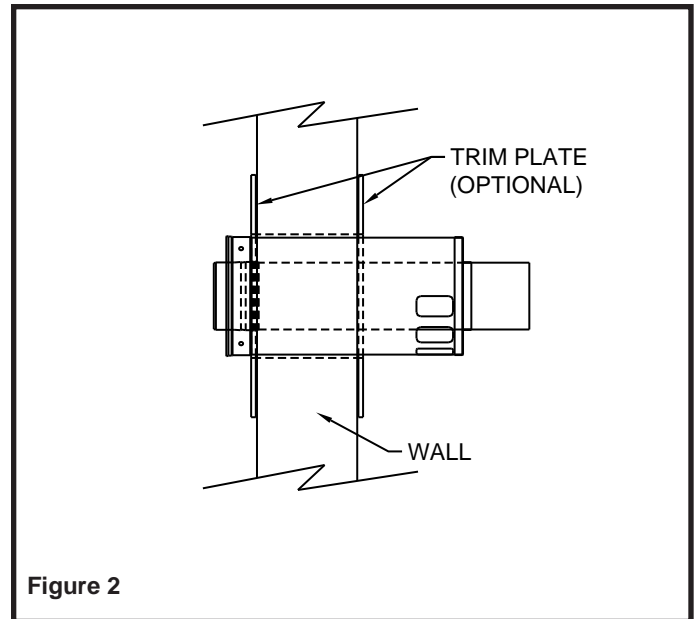

8. Un-cover the water heater and install the 90 degree portion of the vent onto the vent collar of the water heater. (See **Figure 3**). Tighten all clamps to secure this portion of the vent to the appliance.

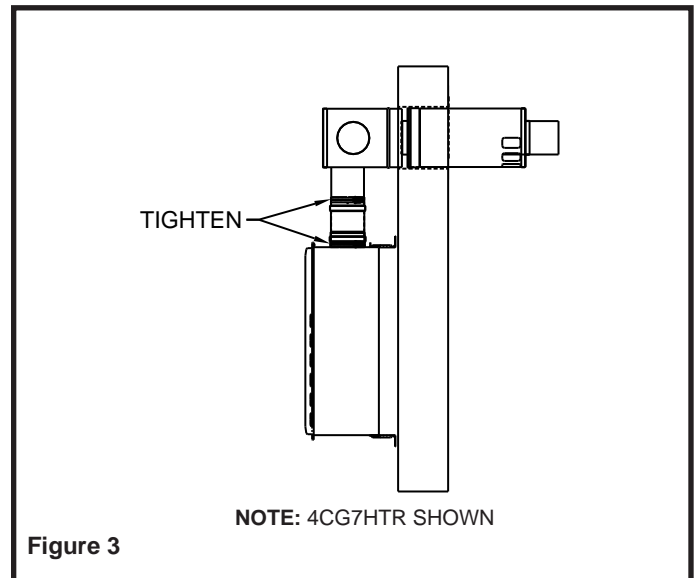

- Connect the vent termination by slipping it into the 90 degree section until the female end stops at the formed bead. Secure the slip fit connection with 3 sheet metal screws provided. The termination must be rotated so that the intake air openings are located on the bottom side (See **Figure 4**). Once connected, verify that the intake air vents on the termination are at least 3 inches from the outer surface of the wall. Most wall mounted water heaters have adjustable mounting brackets to move the heater closer or further from the wall. Make adjustments if needed.

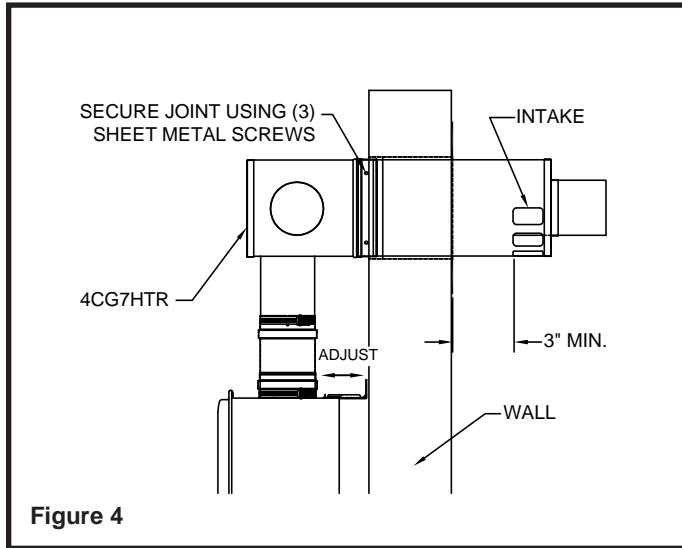

Figure 4

- Using a short section of flexible metal duct, connect the duct to the 4" diameter collar that protrudes from 90 degree vent assembly, using metal clamps or other suitable means. Connect the other end of the duct to the appliance combustion air intake collar. (See **Figure 5**)

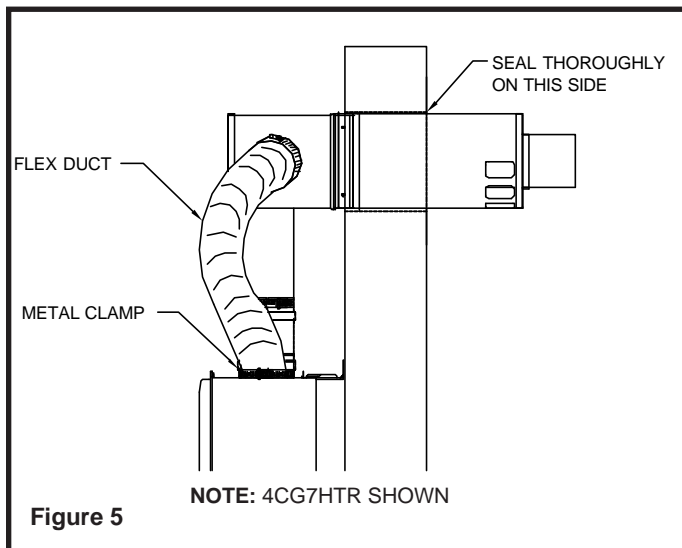

Figure 5

- Using a general purpose silicone sealant approved for outdoor use, apply an adequate bead of sealant around the vent and exterior of the home. Failure to properly seal this wall penetration will result in long term damage due to weather conditions. (See **Figure 5**).

Installation is complete. Refer to manufacturer's water heater instructions for initial operation checks to insure proper operating conditions. For additional information, contact Metal-Fab, Inc. @ 800-835-2830.

4CG7HTL/R Installation:

- For water heaters and boilers that are installed on walls that are adjacent to a wall that will be penetrated, the 4CG7HTL/R termination kit is recommended.
- Locate the wall and point at which the termination will be penetrating the wall. NOTE: Typically an appliance will require a condensate drain near the appliance. The horizontal section of the vent shall be required to slope upwards towards the termination at a 1/4" per foot minimum slope. Take this into account with locating the point of wall penetration.
- As noted on previous steps in these instructions, install the termination through the wall and connect vent and flexible duct as appropriate. Only Metal-Fab Corr/Guard single wall vent is approved for venting to this termination. See **Figure 6** for an example of the final installation.

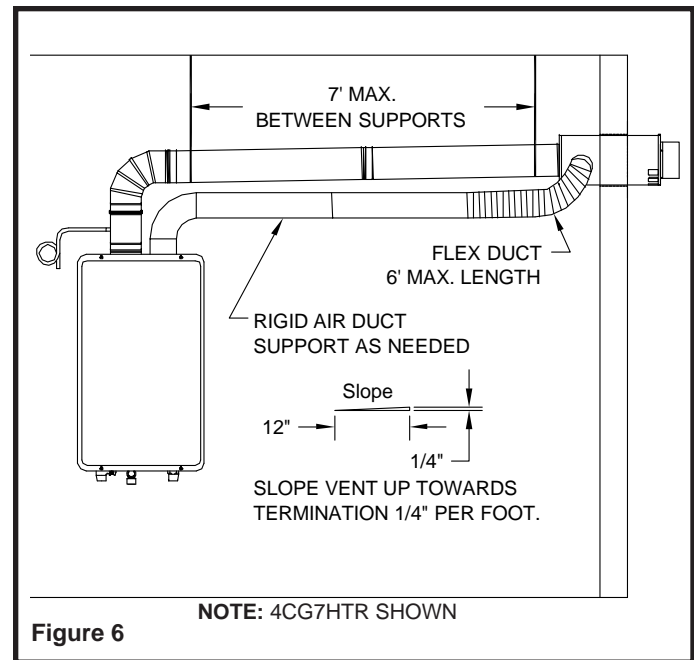

Figure 6

As previously noted be sure to seal penetrations with a general purpose silicone sealant approved for outdoor use. Failure to properly seal this penetration will result in long term damage due to weather conditions. Support venting lengths as per the manufacturer's installation instructions. Provide proper venting slope for horizontal venting and adequate measures to capture and dispose of condensate resulting from extended lengths of venting.

	<p>4CG7HTL/R 4CG7HT90L/R INSTALLATION INSTRUCTIONS</p>
	<p>©2008 Metal-Fab, Inc. Form No. L2449-03/09 8446</p>